

TECHNICAL MANUAL
OPERATOR'S, ORGANIZATIONAL, DIRECT SUPPORT AND GENERAL SUPPORT
MAINTENANCE MANUAL
(INCLUDING REPAIR PARTS AND SPECIAL TOOLS LIST)

FOR

FREQUENCY COMB GENERATOR SG-1129/U

(HP-8406A)

(NSN 6625-00-937-3525)

HEADQUARTERS, DEPARTMENT OF THE ARMY

JUNE 1980

WARNING

115/230 VAC and DC supply wires are exposed when either top or bottom instrument cover is removed.

WARNING

If this instrument is to be energized through an autotransformer (for voltage reduction), make sure the common terminal is connected to the earthed pole of the power source.

BEFORE SWITCHING ON THE INSTRUMENT, the protective earth terminals of the instrument must be connected to the protective conductor of the mains power cord. The mains plug shall only be inserted in a socket outlet provided with protective earth contact. The protection must not be negated by using an extension cord (power (cab) without a protective grounding conductor.

Any interruption of the protective (grounding) conductor, inside or outside the instrument, or disconnection of the protective earth terminal is likely to make this instrument dangerous. Intentional interruption of the earth ground is prohibited.

Servicing this instrument often requires that you work with the instrument's protective covers removed and with ac power connected. Be very careful; the energy at many points in the instrument may, if contacted, cause personal injury.

With the ac power cable connected, the ac line voltage is present at the terminals of the power line module and at the LINE power switch. Be very careful. Bodily contact with this voltage can be fatal.

CAUTION

BEFORE SWITCHING ON THIS INSTRUMENT, make sure instrument's ac input is set to the voltage of the ac power source.

BEFORE SWITCHING ON THIS INSTRUMENT, make sure that all devices connected to the instrument are connected to the protective earth ground.

BEFORE SWITCHING ON THIS INSTRUMENT, make sure the line power (mains) plug is connected to a three-conductor line power outlet that has a protective (earth) ground. (Grounding one conductor of a two-conductor outlet is not sufficient.

BEFORE SWITCHING ON THIS INSTRUMENT, make sure the ac line fuse is of the required current rating and type (normal-blow, time-delay, etc.).



5

SAFETY STEPS TO FOLLOW IF SOMEONE IS THE VICTIM OF ELECTRICAL SHOCK

1

DO NOT TRY TO PULL OR GRAB THE INDIVIDUAL

2

IF POSSIBLE, TURN OFF THE ELECTRICAL POWER

3

IF YOU CANNOT TURN OFF THE ELECTRICAL POWER, PULL, PUSH OR LIFT THE PERSON TO SAFETY USING A DRY WOODEN POLE OR A DRY ROPE OR SOME OTHER INSULATING MATERIAL

4

SEND FOR HELP AS SOON AS POSSIBLE

5

AFTER THE INJURED PERSON IS FREE OF CONTACT WITH THE SOURCE OF ELECTRICAL SHOCK, MOVE THE PERSON A SHORT DISTANCE AWAY AND IMMEDIATELY START ARTIFICIAL RESUSCITATION

This manual contains copyrighted material reproduced by permission
of the Hewlett-Packard Company. All rights reserved.

TECHNICAL MANUAL

No. 11-6625-2847-14&P

HEADQUARTERS
DEPARTMENT OF THE ARMY
Washington, DC 26 June 1980

OPERATOR'S, ORGANIZATIONAL, DIRECT SUPPORT, AND
GENERAL SUPPORT MAINTENANCE MANUAL
INCLUDING REPAIR PARTS AND SPECIAL TOOLS LIST
FOR
FREQUENCY COMB GENERATOR SG-1129/U
(HP-8406A)
(NSN 6625-00-937-3525)
CURRENT AS OF 21 DECEMBER 1979

REPORTING ERRORS AND RECOMMENDING IMPROVEMENTS

You can help improve this manual. If you find any mistakes or if you know of a way to improve the procedures, please let us know. Mail your letter, DA Form 2028 (Recommended Changes to Publications and Blank Forms), or DA Form 2028-2 located in back of this manual direct to: Commander, US Army Communications and Electronics Materiel Readiness Command and Fort Monmouth, ATTN: DRSEL-ME-MQ, Fort Monmouth, New Jersey 07703. A reply will be furnished to you.

TABLE OF CONTENTS

		Page
Section 0	INTRODUCTION	
0-1	Scope	0-1
0-2	Indexes of Publications	0-1
0-3	Maintenance Forms, Records, and Reports.....	0-1
0-4	Administrative Storage.....	0-2
0-5	Destruction of Army Electronics Materiel.....	0-2
0-6	Reporting Equipment Improvement Recommendations (EIR).....	0-2

This manual is an authentication of the manufacturer's commercial literature which, through usage, has been found to cover the data required to operate and maintain this equipment. The manual was not prepared in accordance with military specifications; therefore, the format has not been structured to consider categories of maintenance.

TABLE OF CONTENTS (Continued)

Section	Page	Section	Page
I	GENERAL INFORMATION..... 1-1	IV	THEORY OF OPERATION (cont'd) 4-1
	1-1. Description 1-1		4-14. Step-Recovery Diode..... 4-1
	1-4. Instrument Identification 1-1		4-16. Attenuator Assembly..... 4-1
II	INSTALLATION..... 2-1	V	MAINTENANCE..... 5-1
	2-1. Introduction..... 2-1		5-1. Introduction..... 5-1
	2-3. Unpacking and Inspection..... 2-1		5-3. Test Equipment..... 5-1
	2-5. Storage and Shipment 2-1		5-5. In- Cabinet Performance
	2-8. Rack Installation 2-1		Check. 5-1
	2-12. Operating from 115 or 230 Volts. ... 2-1		5-7. Variable Line Voltage 5-1
			5-9. Instrument Cover Removal 5-1
III	OPERATION 3-1		5-11. Troubleshooting and Repair..... 5-1
	3-1. Introduction..... 3-1		5-12. Preliminary Troubleshooting..... 5-1
IV	THEORY OF OPERATION..... 4-1		5-14. Transistor Troubleshooting..... 5-1
	4-1. General 4-1		5-19. Adjustments..... 5-6
	4-3. Block Diagram..... 4-1	VI	REPLACEMENT PARTS 6-1
	4-5. Individual Circuits..... 4-1		6-1. Introduction..... 6-1
	4-6. 1 MC and 10 MC Oscillators..... 4-1		6-2. Parts Information 6-1
	4-8. 100 MC Oscillator 4-2	VII	SCHEMATIC DIAGRAMS..... 7-1
	4-10. 100 MC Amplifier 4-2		7-1. Introduction..... 7-1
	4-12. Diode Driver and Emitter		7-3. Replacement 7-1
	Follower 4-2	VIII	BACKDATING & MANUAL CHANGES .. 8-1

APPENDICES

	Page
APPENDIX A. REFERENCES.....	A-1
APPENDIX B. COMPONENTS OF END ITEM LIST (Not Applicable).....	
APPENDIX C. ADDITIONAL AUTHORIZATION LIST (Not Applicable).....	
APPENDIX D. MAINTENANCE ALLOCATION	
Section I. Introduction.....	D-1
II. Maintenance Allocation Chart for Frequency Comb	
Generator SG-1129/U (HP-8406A)	D-5
III. Tool and Test Equipment Requirements for Frequency	
Comb Generator SG-1129/U (HP-8406A)	D-6

LIST OF ILLUSTRATIONS

Number	Title	Page
1-1.	Frequency Comb Generator	1-0
2-1.	Combining Case	2-0
2-2.	Adapter Frame	2-1
3-1.	Operating Controls.....	3-0
4-1.	Block Diagram	4-2
5-1.	Test Set-up.....	5-2
5-2.	Location Diagram	5-4
7-1.	Schematic Information Illustration.....	7-1
7-2.	Generator	7-3
7-3.	Power Supply	7-5

LIST OF TABLES

Number	Title	Page
1-1.	Specifications	1-1
5-1.	Test Equipment Required	5-1
5-2.	In-Cabinet Performance Check.....	5-2
5-3.	Performance Check Test Card.....	5-5
5-4.	Safe Ohmmeter Ranges for Transistor Resistance Measurements.....	5-5
5-5.	Output-of-Circuit Transistor Resistance Measurement	5-5
6-1.	Reference Designation Index.....	6-2
6-2.	Replacement Parts	6-7
6-3.	Code List of Manufacturers.....	6-10
6-4.	Part Number-National Stock Number Cross-Reference Index.....	6-11

SECTION 0 INTRODUCTION

0-1. SCOPE

a. This manual contains instructions for the operation, organizational maintenance, direct support, and general support maintenance of the SG-1129/U Frequency Comb Generator, Hewlett-Packard Model HP-8406A, hereinafter referred to as the HP-8406A.

b. This TM is an authentication of Hewlett-Packard manual, HP Part No. 08406-90001, printed June 1967 for HP-8406A with serial prefixes 649 and 737. For HP-8406A with serial prefixes other than 649 or 737 this manual must be corrected in accordance with, Backdating Changes for earlier models, or Manual Changes for later models. Backdating Changes and Manual Changes are located in Section VIII.

c. Appendix A provides a list of applicable references, and Appendix D contains the maintenance allocation chart (MAC). The MAC is current as of 16 May 1979. Table 6-4 contains the part number-national stock number cross-reference index.

0-2. INDEXES OF PUBLICATIONS

a. DA Pam 310-4. Refer to the latest issue of DA Pam 310-4 to determine whether there are new editions, changes, or additional publications pertaining to the equipment.

b. DA Pam 310-7. Refer to DA Pam 310-7 to determine whether there are modification work orders (MWOs) pertaining to the equipment.

0-3. MAINTENANCE FORMS, RECORDS AND REPORTS

a. Reports of Maintenance and Unsatisfactory Equipment. Department of the Army forms and procedures used for equipment maintenance will be those prescribed by TM 38-750, The Army Maintenance Management System.

b. Report of Packaging and Handling Deficiencies. Fill out and forward DD Form 6 (Packaging Improvement Report) as prescribed in AR 735-11-2/NAVSUPINST 4440.127E/AFR 400-54/MCO 4430.3E and DSAR 4140.55.

c. Discrepancy in Shipment Report (DISREP) (SF 361). Fill out and forward Discrepancy in Shipment Report (DISREP) (SF 361) as prescribed in AR 55-38/NAVSUPINST 4610.33B/AFR 75-18/MCO P4610.19C and DLAR 4500.15.

0-4. ADMINISTRATIVE STORAGE

Before placing this instrument in storage, its complete operability must be verified and all deficiencies corrected by accomplishing the performance checks and adjustment procedures in Section V of this manual. Troubleshooting procedures are also provided in Section V to aid in the correction of malfunctions.

0-5. DESTRUCTION OF ARMY ELECTRONICS MATERIEL

Destruction of Army electronics materiel to prevent enemy use shall be in accordance with TM 750-244-2.

0-6. REPORTING EQUIPMENT IMPROVEMENT RECOMMENDATIONS (EIR)

If your Frequency Comb Generator HP-8406A needs improvement, let us know. Send us an EIR. You, the user, are the only one who can tell us what you don't like about your equipment. Let us know why you don't like the design. Tell us why a procedure is hard to perform. Put it on an SF 368 (Quality Deficiency Report). Mail it to: Commander, US Army Communications and Electronics Materiel Readiness Command and Fort Monmouth, ATTN: DRSEL-ME--MQ, Fort Monmouth, New Jersey 07703. We will send you a reply.



Figure 1-1. Frequency Comb Generator

SECTION I
GENERAL INFORMATION

1-1. DESCRIPTION.

1-2. The hp Model 8406A supplies a frequency comb with a selectable spectral line spacing of 1 Mc, 10 Mc, 100Mc, or the frequency of an external trigger signal. The frequency comb generated is usable to at least 4 Gc.

1-3. The Model 8406A provides these additional features:

- a. Output level is continuously variable by a front panel control.
- b. Interpolation amplitude level is continuously variable by a front panel control.
- c. Comb frequency or external trigger frequency is selectable by front panel pushbuttons. This switch will not permit more than one button to be actuated at a time

to avoid confusion in the output signal.

d. Front panel BNC jacks are provided for modulation and external trigger frequencies.

e. A switch is provided on the rear apron to switch the instrument to 230-volt operation.

1-4. INSTRUMENT IDENTIFICATION.

1-5. Hewlett-Packard uses a two-section, eight-digit serial number (on instrument rear panel) to identify instruments (000-00000). The first three digits are a serial prefix number, and the last five digits refer to a specific instrument. If the serial prefix on your instrument does not appear on the title page of this manual, there are differences between the manual and your instrument which are described in a Manual Change sheet included with this manual

Table 1-1. Specifications

Comb Fundamental Frequencies: 1, 10, and 100 Mc, pushbutton selected, generate harmonically related signals usable to beyond 5 Gc.
Comb Frequency Accuracy: $\pm 0.01\%$ (0° to 50°C).
Peak Amplitude*:

	1 Mc Comb	10 Mc Comb	100 Mc Comb
10-500Mc	>-80 dBm	>-60 dBm	-
0.1-1.0 Gc	-	-	>-45 dBm
0.5-2.0 Gc	>-70 dBm	>-50 dBm	-
1-2 Gc	-	-	>-35 dBm
2-4 Gc	>-82 dBm	>-62 dBm	>-47 dBm

*Peak signal level defined in terms of equipment cw signal level (as measured on hp 8551B/851B Spectrum Analyzer).

OUTPUT AMPLITUDE control permits continuous level adjustment.

Comb Output Connector: Type N female, source impedance approximately 50 ohm.

Maximum External Signal at Comb Output: Signals exceeding 1 watt (pk and av) may cause damage.

Interpolation Function: 10- Mc and 1-Mc combs can be combined into primary- secondary comb; Interpolation Amplitude control adjusts level of secondary (1 Mc) signal.

External Modulation: External modulation signals can be used to phase modulate any of the combs to produce sidebands for interpolation between fixed comb markers¹. BNC female connector.

External Trigger: External signals (normally sine waves) between 1 Mc and 200 Mc can be used to produce combs spaced at frequency of trigger signals². BNC female connector.

Power: 115 or 230 volts $\pm 10\%$, 50-400 cps, 2 watts

Dimensions:

NOTE
DIMENSIONS IN INCHES AND (MILLIMETERS)
(A) FOR TOTAL LENGTH INCLUDING KNOBS
R20 F14L 125 MM
(B) FOR HEIGHT INCLUDING FEET
R20 77/16 IN. 111 MM

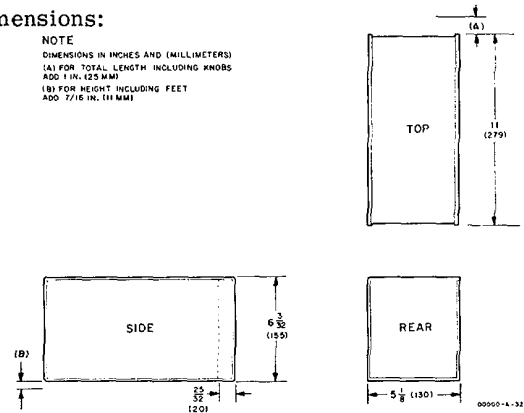

Weight: Net 6 lb (2.7 Kg); shipping 9 lb (4.1 Kg)

¹External modulation: Modulation frequencies can be as low as 5 kc. Although the level of modulation voltage required varies with modulating frequency and the harmonic number of the comb being modulated, the information here will serve as a guide:

To produce sidebands approximately 20 db below the main comb marker at the 1 Gc harmonic of the appropriate comb (comb output amplitude at maximum), typical modulation voltages are:

1-2	mv rms at 200 kc for the	1 Mc comb
5-10	mv rms at	2 Mc for the 10 Mc comb
50-100	mv rms at	20 Mc for the 100 Mc comb

Signals greater than 5v rms at modulation input may cause damage.

²External Trigger: Typical input signal levels to generate externally triggered combs at the frequency of the external trigger are in the range of 1-3 volts rms. Input signals greater than 5 volts rms may cause damage. With input triggers in the 1-20 Mc frequency span, the OUTPUT AMPLITUDE control of the 8406A can be used to adjust the output comb level. When using signals in the frequency span from 20-200 Mc, output comb amplitude is a function of the input signal level.

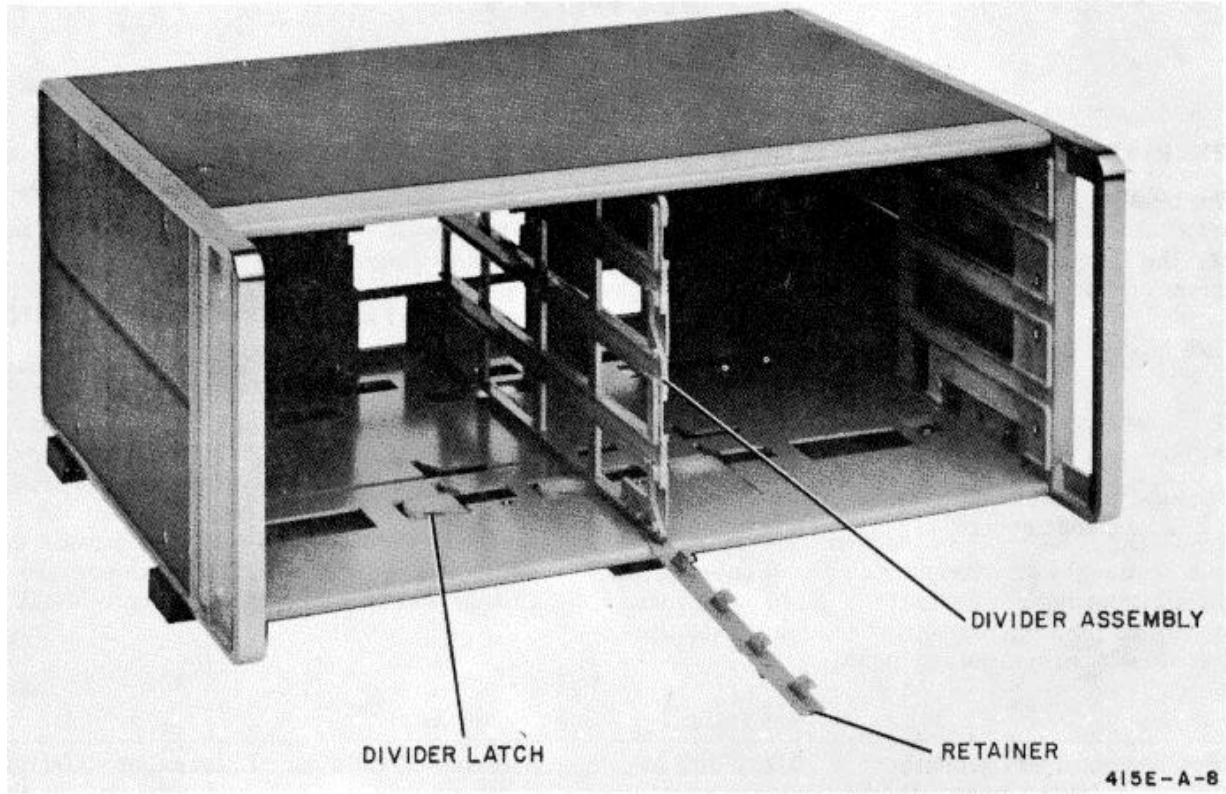

STEP ①
SLIDE TOP PART
TO LIMIT

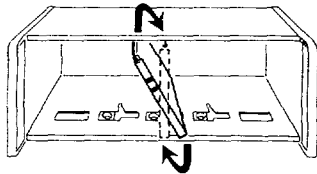

STEP ②
SLIDE BOTTOM PART
TO LIMIT

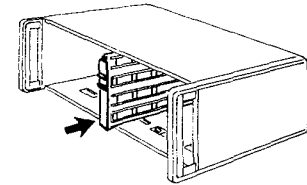

STEP ③
PUSH IN TO LIMIT

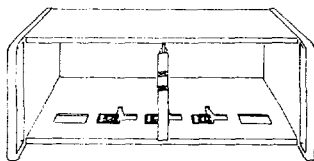

STEP ④
SLIDE OVER TO LIMIT

STEP ⑤
PUSH DOWN
TO RELEASE

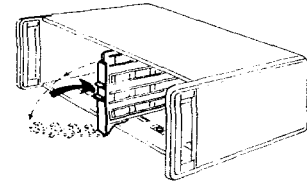

STEP ⑥
PLACE INSTRUMENT
INTO CASE

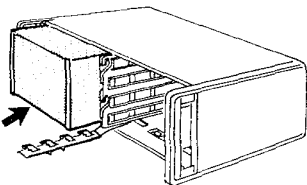

STEP ⑦
SET RETAINER
BACK INTO PLACE

STEP ⑧
PUSH UP TO LOCK

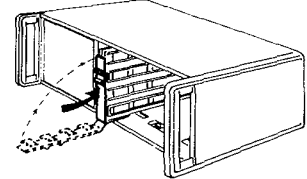

00000-8-1

Figure 2-1. Combining Case

**SECTION II
INSTALLATION**

2-1. INTRODUCTION.

2-2. This section contains information on unpacking, inspection, repacking, storage and installation.

2-3. UNPACKING AND INSPECTION.

2-4. Inspect instrument for shipping damage as soon as it is unpacked. Check for broken knobs and connectors; inspect cabinet and panel surfaces for dents and scratches. A performance check is given in Table 5-2.

DELETED

2-5. STORAGE AND SHIPMENT.

2-6. DELETED

2-8. RACK INSTALLATION.

2-9. When the Model 8406A is to be rack-mounted, a combining case (Paragraph 2-10) or adapter frame (Paragraph 2-11) is required. The two methods for rack mounting are discussed in the following paragraphs.

2-10. COMBINING CASE. The combining case (hp 1051A) shown in Figure 2-1 is a full-module unit which accepts varying combinations of submodule units such as the 1/3 module Model 8406. The combining case can be used as a bench model or it can be rack-mounted. A rack-mounting kit (hp part number 5060-0777) is supplied to rack mount the combining case. Instructions for using the case are given in Figure 2-1. When only one-third of the case is used, a blank fillerpanel (hp part number 5060-0793) is available to enclose the unused front panel space.

2-11. ADAPTER FRAME. The adapter frame (hp part number 5060-0797) in Figure 2-2 is a rack frame that accepts any combination of submodule units;

a. Place adapter frame on edge of bench as shown in step 1, Figure 2-2. (Only two submodule units are illustrated for clarity. The method of operation is the same for three.)

b. Stack units in frame as shown in step 2. Place spacer clamp between units, step 3.

c. Place end spacer clamps as shown in step 4, and push units into frame.

d. Insert screws on either side of frame, step 5, and tighten until units are tight in frame.

e. The complete assembly is now ready for rack mounting.

2-12. OPERATING FROM 115 OR 230 VOLTS.

2-13. The Model 8406 may be operated from either 115- or 230-volt 10%,50-to 400-cps power lines. A slide switch on the rear panel permits quick conversion for operating from either voltage. Insert a narrow-blade screwdriver in the switch slot and slide the switch to expose "115" marking for 115-volt operation or "230" marking for 230-volt operation. A 1/16 amp fuse is used for both voltages.

CAUTION: Be sure this switch is in proper position before turning on.

2-14. POWER CABLE. The Model 8406 is equipped with a detachable 3-wire power cable. Proceed as follows for installation:

a. Connect flat plug (three-socket connector) to ac line jack at rear of instrument.

b. Connect plug (two-blade with round grounding pin) to three-wire (grounded) power outlet. Exposed portions of the instrument are grounded for safety; when only a two-blade outlet is available, use connector adapter (hp part number 1251-0048), and connect short wire from side of adapter to ground.

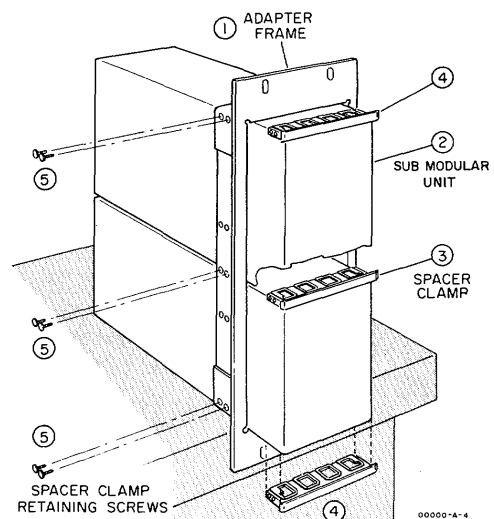
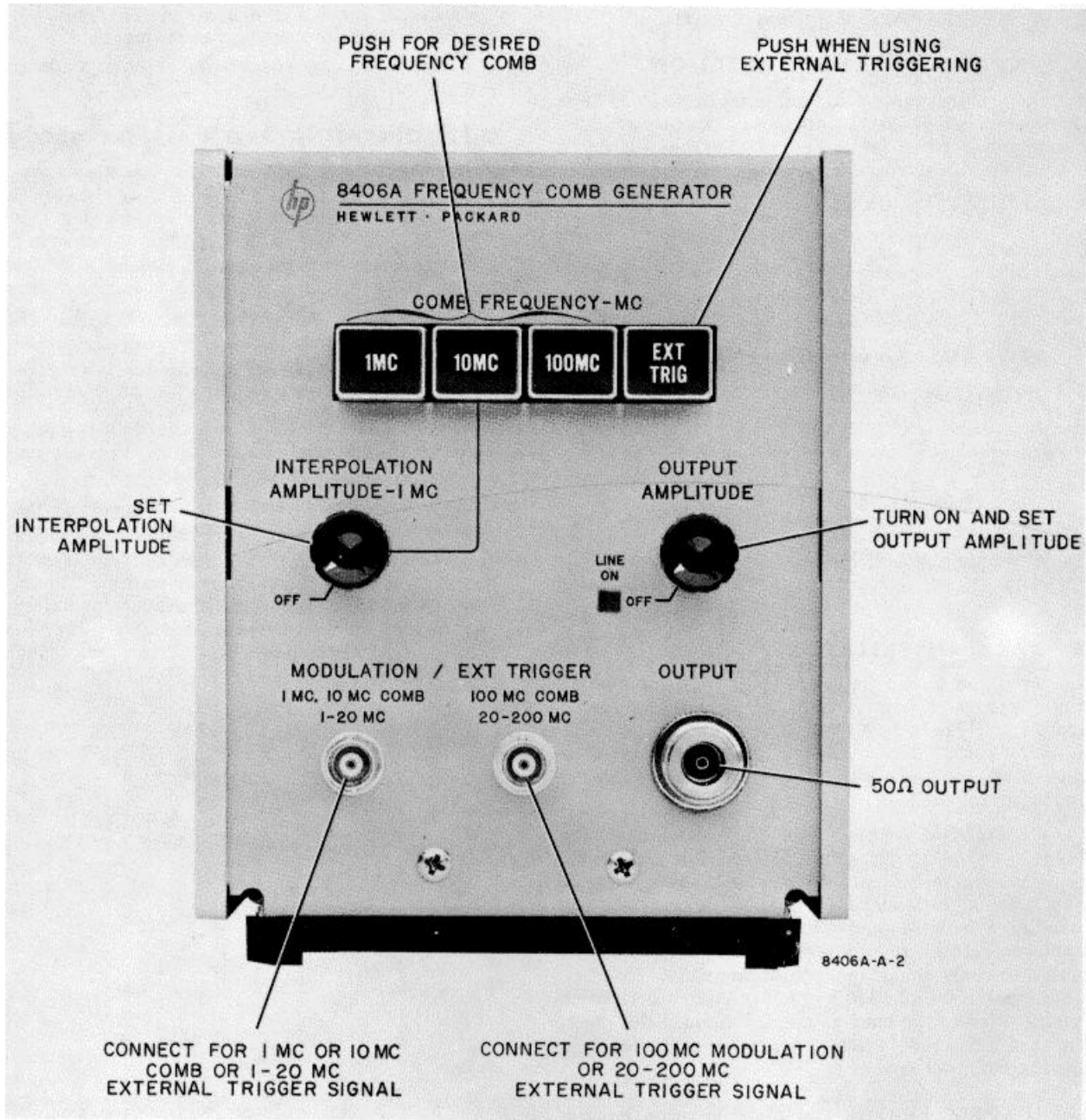

Figure 2-2. Adapter Frame



02293-1

**SECTION III
OPERATION****3-1. INTRODUCTION.**

3-2. The Model 8406 Frequency Comb Generator is used to calibrate other instruments which display the frequency domain. It is usually used with Spectrum Analyzers to calibrate their frequency and output characteristics. The illustration on the facing page, Figure 3-1, shows in general the operation of the Model 8406. The following paragraphs discuss special points which are not covered in the general explanation.

3-3. INTERPOLATION MODULATION. Usually to calibrate an instrument, the 10-Mc comb is used first to determine which lines correspond to the 10-Mc markers. If a finer determination is required, the INTERPOLATION AMPLITUDE control is turned on and the amplitude adjusted. This will give ten times more lines, each marking a 1-Mc point, in addition to the 10-Mc lines. If the 1-Mc Oscillator only were used, the same accuracy would be obtained but there is the possibility that a wrong line would be chosen if the instrument being tested is badly out of calibration.

3-4. EXTERNAL MODULATION. If a modulation spectrum other than 1 Mc on the internally generated comb is desired, feed the output from an external oscillator into the appropriate MODULATION jack (1 Mc and 10 Mc or 100 Mc COMB). The level should be adjustable around 10 millivolts. Depress the COMB FREQUENCY pushbutton for the main frequency spectrum desired. The output will now contain major spectral lines spaced at the frequency of the external oscillator.

3-5. FREQUENCY CONSIDERATIONS. At low levels of modulation (phase modulation), a single pair of sidebands appear - variable with modulation for precise frequency determination. At higher levels of modulation more sidebands appear which permit calibration of devices (spectrum analyzers, frequency meters, etc.) in arbitrary frequency increments. As with all modulation, the absolute accuracy of the generator must be increased by the multiple of the harmonic used in order to obtain the required accuracy at the operating frequency (the percentage accuracy is the same for all harmonics).

3-6. EXTERNAL TRIGGER. The external trigger voltage is fed in by means of the EXT TRIGGER jacks, either 1- 20 Mc or 20- 200 Mc, depending upon frequency. The signal used for external triggering should be adjustable in amplitude around 2 volts. Note that in the EXTERNAL TRIGGER position the OUTPUT AMPLITUDE control is operable when the signal is fed into the 1-20 MC EXT TRIGGER jack. The OUTPUT AMPLITUDE control may be used to adjust the output level when this jack is used. If the 20-200 Mc jack is used, the output level must be adjusted by varying the input level of the external trigger signal. The input from this jack does not go through the Diode Driver and therefore the OUTPUT AMPLITUDE control will have no effect. In fact, the instrument does not even have to be on if the 20-200 Mc jack is used. However, more power is needed (10-20 millivolts).

**SECTION IV
THEORY OF OPERATION****4-1. GENERAL.**

4-2. The Model 8406 generates a train of sharp pulses at a repetition frequency of 1 Mc, 10 Mc, or 100 Mc supplied internally or at the frequency of an external oscillator. The frequency spectrum of the output is a comb with spectral lines spaced by the repetition frequency, 1-Mc, 10-Mc, 100-Mc or the frequency of an external oscillator.

4-3. BLOCK DIAGRAM.

4-4. Figure 4-1 is a block diagram which shows the interconnections between the main sections of the instrument. Note that only one oscillator is on at any one time, except when the 1-Mc Interpolation Oscillator is used to interpolate between the main spectral lines of the 10-Mc Oscillator. In the case of the 1-Mc and 10-Mc Oscillators the signal is passed through a Diode Driver before it is applied to the Output Harmonic / Generator (low-frequency signals do not generate harmonics with sufficient amplitude when applied directly to the Output Harmonic Generator). The Diode Driver sharpens the transition so that higher amplitude

harmonics are generated. The 100-Mc Oscillator-Amplifier generates high-level harmonics without shaping and thus triggers the step-recovery diode directly.

4-5. INDIVIDUAL CIRCUITS.**4-6. 1-MC AND 10-MC OSCILLATORS.**

4-7. Since these oscillators are similar they will be described together. Both of these oscillators consist of a Colpitts-type oscillator in a common-emitter configuration. Crystal control is used in both oscillators. The output of the 10-Mc Oscillator goes directly to the Diode Driver. Output of the 1-Mc Oscillator goes either directly to the Diode Driver or to the 5-Mc Harmonic Generator Diode A1CR1. The filter following removes all harmonics above 5 Mc when the 1-Mc signal is used for interpolation between the spectral lines of the 10-Mc Oscillator. The Interpolation Oscillator phase-modulates the 10M/c signal producing upper and lower sidebands. Line overlap would be produced if signals above 5 Mc were used for modulation.

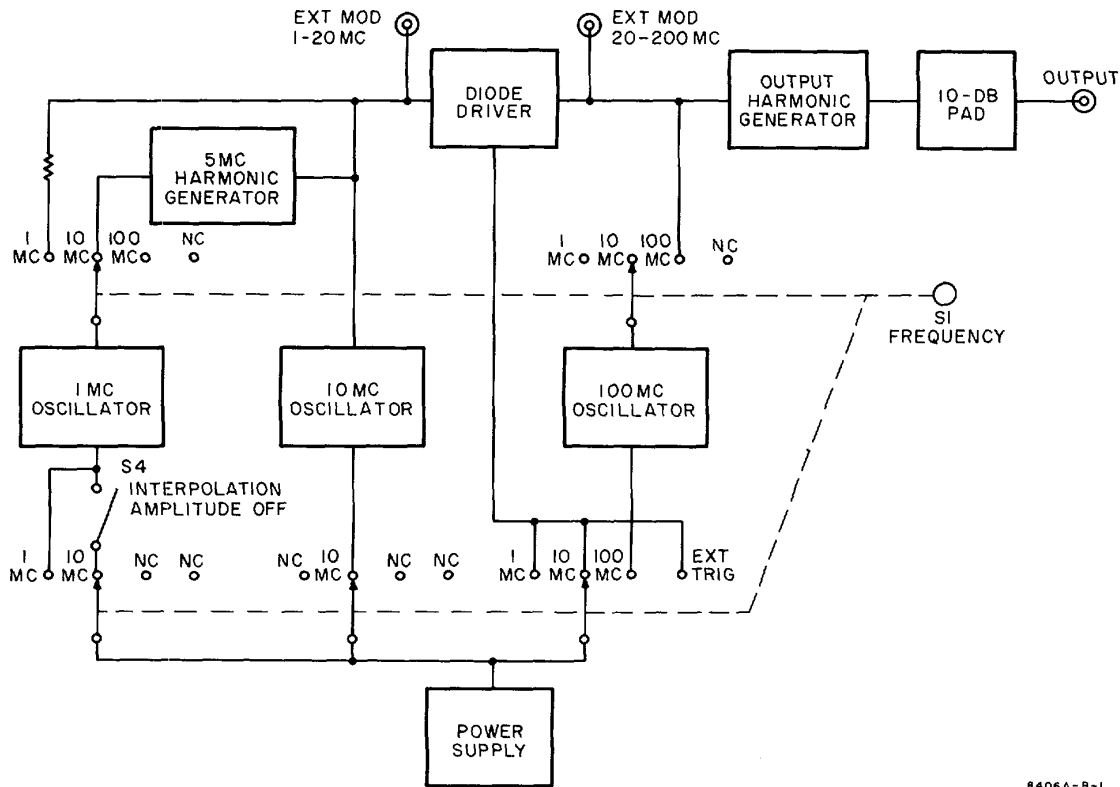

Figure 4-1. Block Diagram

To reduce the confusion caused by two sets of signals, only modulating frequencies 5 Mc or below are permitted to modulate the 10- Mc signal.

4-8. 100-MC OSCILLATOR.

4-9. This oscillator is also of the Colpitts type with a tuned tank circuit. Series tuning of the crystal is used to adjust the frequency.

4-10. 100-MC AMPLIFIER.

4-11. This Amplifier is of standard configuration with a tuned input and a tuned output. The Amplifier is energized only in the 100-Mc switch position, since it is not needed otherwise.

4-12. DIODE DRIVER AND EMITTER FOLLOWER.

4-13. The Diode Driver generates a fast-rise pulse for each cycle sine wave fed to the tunnel diode, CR2. This fast-rise pulse produces a large current in the reverse direction of the Output Harmonic Generator, CR1. When the stored charge in the diode is depleted, the diode opens, producing a step of voltage on the transmission line of the Harmonic Generator. The Emitter Follower is used as a source of variable voltage

to the Diode Driver. As the output of the Diode Driver is varied, the level of the output frequency comb varies.

4-14. STEP-RECOVERY DIODE.

4-15. Diode CR1 is a step-recovery diode used for harmonic generation. Step-recovery diodes operate somewhat differently than normal diodes. In the forward-biased condition they act as any diode. However when back-biased, these diodes continue to conduct due to stored carriers. When the diode runs out of stored carriers it shuts off abruptly. This sharp cutoff generates a multitude of harmonics. The step function produced is formed into a impulse by the shorted transmission-line stub at the diode output. The diode must conduct in the forward direction after each pulse to replace the stored charge. A biasing network (R19, L10) sets the voltage at the diode so that conduction takes place. The step-recovery diode may be used by itself for harmonic generation. This is the situation when using the 20-200 MC EXTERNAL TRIGGER jack. For this application the instrument does not have to be turned on.

4-16. ATTENUATOR ASSEMBLY.

4-17. This attenuator isolates the step-recovery diode from the output connector to give a 50-ohm output impedance.

**SECTION V
MAINTENANCE**

5-1. INTRODUCTION.

5-2. This section provides maintenance and service information for the Model 8406 Frequency Comb Generator. Included are a table of recommended test equipment, troubleshooting procedures, repair and adjustment procedures, and an in-cabinet performance check which may be used to verify proper operation of the Generator.

5-3. TEST EQUIPMENT.

5-4. Recommended test equipment for performance checking, troubleshooting, and repair is listed in Table 5-1. Other test instruments may be used if their specifications satisfy the required characteristics. See Section II of Appendix D, MAC.

5-5. IN-CABINET PERFORMANCE CHECK.

5-6. GENERAL. The In-Cabinet Performance Checks, Table 5-2, and Performance Check Test Card (to be filled out during incoming inspection), verify specifications and provide a permanent record of the performance of the instrument. The In-Cabinet

Performance Check verifies the proper operation of all circuits in the Generator and may be used:

- a. As part of an incoming inspection check of instrument specifications;
- b. periodically, for instruments used in systems where maximum reliability is of utmost importance;
- c. as part of a troubleshooting procedure to locate out-of-tolerance operation;
- d. after any repairs or adjustments, before returning instrument to regular service.

5-7. VARIABLE LINE VOLTAGE.

5-8. During the Performance Check, Table 5-2, connect the Generator to a power source through a variable voltage device so that line voltage may be varied $\pm 10\%$ from nominal (115 or 230Vac) to assure proper operation of the Generator under various supply conditions.

Refer to Section II of Appendix D, MAC.

Table 5-1. Test Equipment Required

Instrument Type	Critical Specifications	Instrument Recommended
AC Voltmeter	Range: to 1 mV.	hp Model 400D/H/L/E/EL
	Frequency Range: 40-200 cps	
DC Voltmeter	Range: 14 volts	hp Model 405BR
	Resolution: 0.2 volts	
Electronic Counter	Range: 1 to 100 Mc	hp Model 5254L with
	Accuracy: $\pm 0.005\%$	hp Model 5253B plug-in
Spectrum Analyzer	Range: 10 Mc- 4 Gc	hp Model 8551 with
hp Model 851		
Notch Filter	Rejects 2 Gc	hp Model 8439A
RF Voltmeter	Range: 100 Mc	hp Model 411A
Variable Autotransformer	Power: 1 amp	Ohmite VT8F
	Voltage: 102 to 128 volts	
Signal Generator	Range: 200 Kc to 50 Mc	hp Model 606
Signal Generator	Frequency: 1-2 Gc	hp Model 8614A
Bandpass Filter	Pass: 2-4 Gc, reject other	hp Model 8431A
ACCESSORIES		
UG-274A/U	BNC T Connector	hp part number 1250-0072
UG-349A/U	Female N-Male BNC connector	hp part number 1250-0077
Tuning Wand		Walsco 2947
Plastic Tuning Wand		General Cement Company
		GC 8271

Table 5-2. In-Cabinet Performance Check

OUTPUT

- a. Connect 1-2 Gc Signal Generator to Notch Filter at the input to the Spectrum Analyzer.
- b. Set Spectrum Analyzer controls as follows:

TUNE.....	1 Gc (.01-2 Ge FREQUENCY range)
IF	2 Gc
VERT DISPLAY	LOG
SWEEP TIME	1 SEC/CM
SPECTRUM WIDTH.....	200 MC/CM
ATTENUATOR.....	10 DB (to start)
IF BANDWIDTH.....	10 KC
- c. Set Signal Generator for -35-dBm output at 1 Gc.
- d. Adjust the Spectrum Analyzer for a display 6 cm high.
- e. Increase the Signal Generator frequency at approximately 200-Mc intervals to 2 Gc, observing the display amplitude at each frequency. If the amplitude changes, mark the level with a grease pencil on the face of the Spectrum Analyzer.
- f. Connect the 8406A as shown in Figure 5-1.

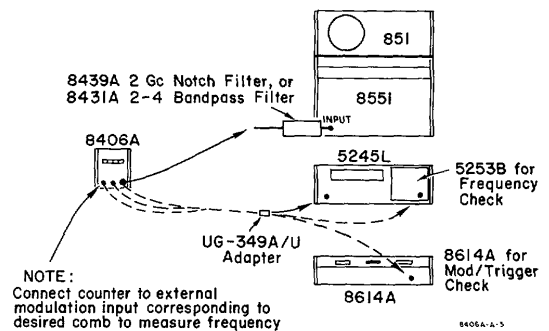

- h. Leave Spectrum Analyser controls as in b and d. The frequency comb should be smooth in output with an output level of greater than -35 dBm from 1-2 Gc and greater than -45 dBm from 100 Mc to 1 Gc.
- i. Depress the 10 Mc pushbutton on the 8406.
- j. The frequency comb should be smooth in output with an output level of greater than -50 dBm from 500 Mc to 2 Gc and greater than -60 dBm from 10 Mc to 500 Mc.
- k. Depress the 1 Mc pushbutton on the 8406.
- m. The frequency comb should be smooth in output with a level of greater than -70 dBm from 500 Mc to 2 Gc and greater than -80 dBm from 10 Mc to 500 Mc (ATTENUATOR may have to be switched to 0 DB).
- n. Connect the counter and measure the frequency. Must be within 100 cycles.
- o. Depress the 10 MC pushbutton on the 8406. The frequency must be within 1000 cps.
- p. Depress the 100 MC pushbutton on the 8406. The frequency must be within 10 kc.
- q. Set the Spectrum Analyzer so that two successive 10-Mc harmonics are displayed, widely spaced.
- r. Turn the INTERPOLATION AMPLITUDE control on the 8406 fully clockwise. Ten 1-Mc pulses should appear in the space between the two 10-Mc pulses.

If it is desired to check the output level from 2-4 Gc, fundamental mixing must be used to increase sensitivity in order that the lower levels may be observed. Proceed as follows:

- a. Repeat Analyzer Calibration steps a-d, using a 2-4 Gc Signal Generator with a 8431A Bandpass Filter and set the Spectrum Analyzer controls as follows:

TUNE.....	2.8/3.2Gc (1.8-4.2 Gc FREQUENCY range)
IF	200 Mc
VERT DISPLAY	LOG
SWEEP TIME	1 SEC/CM
SPECTRUM WIDTH	200 MC/CM
ATTENUATOR.....	10 DB (to start)
IF BANDWIDTH.....	10 Kc

Table 5-2. In-Cabinet Performance Check (cont'd)

b. Measure 8406 comb output level,	100-Mc comb should be greater than -47 dBm over 2-4 Gc range 10-Mc comb should be greater than -62 dBm over 2-4 Gc range 1-Mc comb should be greater then -82 dBm over 2-4 Gc range (may have to reduce ATTENUATOR to 0 DB to see this sensitivity on last measurement).
MODULATION/EXT 1-20 MC Input	
<p>a. Connect the instrument as shown in Figure 5-1.</p> <p>b. Depress the 1 Mc pushbutton.</p> <p>c. Set the Spectrum Analyzer to a center frequency of 1 Gc and a spectrum width of about 3 Mc with an IF bandwidth of 1 Kc.</p> <p>d. Connect a Signal Generator to 1 MC, 10 MC COMB MODULATION jack on 8406.</p> <p>e. Set frequency of signal generator to 200 Kc and adjust output amplitude so that the sidebands displayed on Spectrum Analyzer are 20 db below the amplitude of the 1 -Mc comb.</p> <p>f. Read the output level of the signal generator. This level should be less than 1 mV. (Actual modulating voltage required will be approximately twice this since the input impedance at this jack is high.)</p> <p>g. Depress the 10 MC pushbutton on the 8406.</p> <p>h. Set the Spectrum Analyzer to a spectrum width of 100 Mc and an IF bandwidth of 10 Kc.</p> <p>i. Set the frequency of signal generator to 2 Mc and level so that the sidebands displayed on spectrum analyzer are 20 db below carrier frequency. Signal Generator output level should be less than 6 mV.</p> <p>j. Insert a BNC T connector at the 1-20 Mc input and connect an RF Millivoltmeter to the open arm of the T to measure the input signal.</p> <p>k. Depress EXT TRIG pushbutton on 8406, set Signal Generator to 20 Mc and increase output level until 8406 triggers. This level should be less than 4 volts.</p> <p>m. Connect Signal Generator to the 100 MC COMB MODULATION jack of 8406 with the same set-up as in step k.</p> <p>n. Depress 100 MC pushbutton on 8406, set Signal Generator to 20 Mc and increase output level until 8406 triggers. This level should be less than 200 mV.</p> <p>o. Set Signal Generator frequency to 50 Mc, depress EXT TRIG pushbutton on 8406, and increase output level of Signal Generator until Comb Generator triggers. This level should be less than 2 volts.</p>	

CAUTION
TO AVOID DAMAGE, REMOVE POWER FROM INSTRUMENT BEFORE REMOVING OR REPLACING INSTRUMENT COVERS, ASSEMBLIES, OR COMPONENTS.

5-9. INSTRUMENT COVER REMOVAL.

5-10. To remove top or bottom cover, unscrew and remove the countersunk Phillips-head screws which secure cover to the instrument at the rear. Then slide cover toward rear of instrument.

WARNING: 115/230 VAC AND DC SUPPLY WIRES ARE EXPOSED WHEN EITHER TOP OR BOTTOM INSTRUMENT COVER IS REMOVED. BE CAREFUL DURING TROUBLESHOOTING, ADJUSTMENTS, OR REPAIR.

5-11. TROUBLESHOOTING AND REPAIR.

5-12. PRELIMINARY TROUBLESHOOTING.

5-13. The first step is to decide if the trouble is catastrophic or marginal. If catastrophic, start with the power supply and then trace the signal through the

instrument (the block diagram, Figure 4-1, will help here). If marginal, perform the In-cabinet Performance Check to determine the circuit which is causing the marginal performance. The instrument is straightforward except for the Diode Driver. Note that the Diode Driver is energized in the EXT TRIG position of the COMB FREQUENCY switch in addition to the 1 MC and 10 MC positions. This permits the use of the Diode Driver to "square" up the incoming trigger signal when using external trigger.

5-14. TRANSISTOR TROUBLESHOOTING.

5-15. When troubleshooting transistor circuits certain precautions must be observed. Transistors can be damaged by small voltages or by heat. Be very careful not to short the circuit and thereby apply excessive voltage to the transistors. When using a VTVM measure emitter-to-base voltages to a common point, such as the chassis (there may be enough loop current between the leads of the VTVM to damage transistors). When measuring resistance use only the ranges on the ohmmeter which have 1.5 volts or less between the leads and whose short-circuit current is less than 3 mA. See Table 5-4 for the safe ranges of popular ohmmeters.

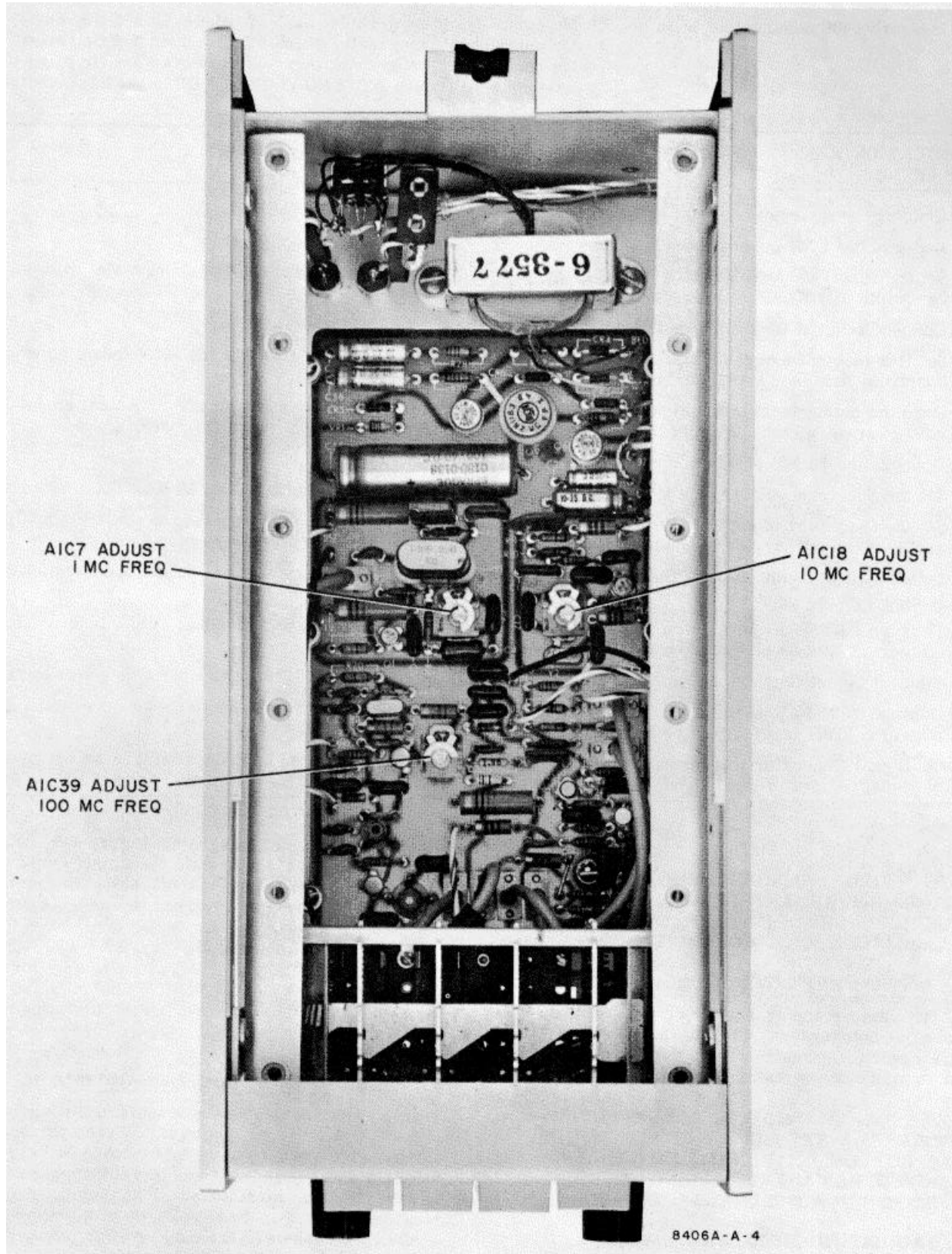

Figure 5-2. Location Diagram

Table 5-3. Performance Check Test Card

Description			
<u>Output</u>			
100 Mc	Level deviation ±	db	
	Frequency		
10 Mc	Level deviation ±	db	
	Frequency		
1 Mc	Interpolation frequency		
	Frequency		
Modulation/External Trigger			
<u>1-20 Mc Input</u>			
200 Kc	Input level	volts	
2 Mc	Input level	volts	
20 Mc	Input level	volts	
<u>2-200 Mc Input</u>			
20 Mc	Trigger voltage	volts	

5-16. IN-CIRCUIT TESTING. The most common causes of transistor failures are internal short- and open-circuits. In transistor circuit testing the most important consideration is the transistor base-emitter junction. Like the control grid of a vacuum tube, the base is the control point of the transistor. The emitter-base voltage should be a fraction of a volt, the polarity and exact value depending upon the material

Table 5-4. Safe Ohmmeter Ranges for Transistor Resistance Measurements

Ohmmeter	Safe Range(s)	Open Ckt Voltage	Short Ckt Current	Lead	
				Color	Polarity
HP 412A	Rx 1K	1.0V	1 ma	Red Black	+ -
	Rx 10K	1.0V	100 µa		
	Rx 100K	1.0V	10 µa		
	Rx 1M	1.0V	1 µa		
	Rx 10M	1.0V	0.1 µa		
HP 410C	Rx 1K	1.3V	0.57 ma	Red Black	+ -
	Rx 10K	1.3V	57 µa		
	Rx 100K	1.3V	5.7 µa		
	Rx 1M	1.3V	0.5 µa		
	Rx 10M	1.3V	0.05 µa		
HP 410B	Rx 100	1.1V	1.1 µa	Black Red	+
	Rx 1K	1.1V	110 µa		
	Rx 10K	1.1V	11 µa		
	Rx 100K	1.1V	1.1 µa		
	Rx 1M	1.1V	0.11 µa		
Simpson 260	Rx 100	1.5V	1 ma	Red Black	+ -
Simpson 269	Rx 1K	1.5V	0.82ma	Black Red	+
Triplet 630	Rx 100	1.5V	3.25 mA	Varies with Serial Number	
	Rx 1K	1.5V	325 µA		
Triplet 310	Rx 10	1.5V	750 µa		
	Rx 100	1.5V	75 µa		

of the transistor and the current carried. Short the emitter to the base. If the transistor is working, the voltage on the collector should go toward the supply voltage.

5-17. OUT-OF-CIRCUIT TESTING. While it is not recommended to remove the transistors from the instrument for troubleshooting as a general rule, sometimes it is impossible to isolate troubles to a particular transistor. In such case it may be necessary to remove the suspected transistor and test it on a curve tracer. Do NOT remove a transistor for testing without some indication that this particular transistor is at fault. Use a heat sink, such as a pair of long-nosed pliers, between the soldering iron and the transistor. When soldering a transistor back in the circuit use the same precautions as when unsoldering. If a particular transistor is all right but the circuit still does not work, try the transistor ahead and behind the suspected one. Table 5-5 gives typical resistance measurements of transistors.

5-18. PRINTED CIRCUIT COMPONENT REPLACEMENT. Component lead holes in the Model 8406 circuit board have plated walls to ensure good electrical contact between conductors on the opposite sides of the board. To prevent damage to this plating and to the replacement component, apply heat sparingly and work carefully. The following replacement procedure is recommended;

- a. Remove defective component.
- b. Melt solder in component lead holes. Use clean, dry soldering iron to remove excess solder. Clean holes with toothpick or wooden splinter. Do not use metal tool for cleaning as this may damage through-hole plating.

Table 5-5. Output-of-Circuit Transistor Resistance Measurement

Transistor Type	Connect Ohmmeter		Measure Resistance (ohms)
	Pos. lead to	Neg. lead to	
PNP Germanium	Small Signal emitter	base*	200-500
	Signal emitter	collector	10K-100K
Power	emitter	base*	30-50
	emitter	collector	several hundred
Small Signal	base	emitter	1K-3K
	collector	emitter	very high (might read open)
NPN Silicon	base	emitter	200-1000
	Power collector	emitter	high, often greater than 1M

*To test for transistor action, add collector-base short. Measured resistance should decrease.

Section V
Paragraphs 5-19 to 5-22

c. Bend lead of replacement component to correct shape and insert component leads into lead holes. Using heat and solder sparingly, solder leads in place. Heat may be applied to either side of the board. Use heat sink (long-nose pliers, commercial heat-sink tweezers, etc.) when replacing transistors and diodes in order to prevent conduction of excessive heat from the soldering iron to the component. Firm application of heat for the shortest possible time is the rule.

d. Through-hole plating breaks are indicated by the separation from the board of the round conductor pad on either side of the board. To repair breaks, press conductor pads against board and solder replacement component lead to conductor pad on both sides of the board.

5-19. ADJUSTMENTS.

5-20. Rarely, if ever, will it be necessary to perform adjustments on a particular instrument. Do NOT perform these adjustments as a performance check. Use the performance check. Test limits given here should not be construed as part of the specifications.

5-21. POWER SUPPLY. Perform the following tests at either 115 or 230 volt 50-400 cps, unless otherwise noted. When line voltage variations are specified, the test limits apply at the following voltages:

	<u>115 VOLTS</u>	<u>230 VOLTS</u>
Low line	103 volts	207 volts
Normal line	115 volts	230 volts
High line	127 volts	253 volts

Proceed as follows:

- a. Depress 10 MC COMB FREQUENCY pushbutton.
- b. Set INTERPOLATION AMPLITUDE fully clockwise.

02293 -2

- c. Set OUTPUT AMPLITUDE fully clockwise.
- d. Connect a dc and an ac voltmeter to the -14 volt supply. This is a violet wire on top of the printed circuit, third terminal from the rear (see Figure 5-2 for location).

e. Vary the line voltage from low to high while watching the meters. The dc voltage should stay in regulation within 0.5Vdc and the ac voltage (ripple) should be below 3 millivolts.

5-22. OSCILLATOR FREQUENCIES. Connect the instrument as shown in Figure 5-1. The 2 Gc Notch Filter prevents overloading of 851/8551 Spectrum Analyzer at the intermediate frequency, but may not be necessary with all Spectrum Analyzers. Set Generator controls as follows:

COMB FREQUENCY 100 MC
 INTERPOLATION AMPLITUDEOFF
 OUTPUT AMPLITUDE fully clockwise

a. Set Spectrum Analyzer to a center frequency of 1 Gc with spectrum width of 2 Gc. The frequency comb should be smooth in output. If not, tune A1T1 (see location diagram, Figure 5-2) with a Walsco 2547 tuning wand for a stable frequency and A1T2 for maximum flat output in the 400-Mc region as the OUTPUT AMPLITUDE control is varied from maximum to minimum.

b. Connect counter and tune A1C39 (see location diagram, Figure 5-2) for 100-Mc frequency.

c. Depress 10 Mc pushbutton and use counter to measure frequency. Tune A1C18 with a General Cement 8271 plastic tuning wand to 10 Mc.

d. Depress 1 Mc pushbutton and use counter to measure frequency. Tune A1C7 to 1 Mc.

SECTION VI
REPLACEABLE PARTS

See Table 6-4, PART NUMBER-NATIONAL STOCK NUMBER CROSS-REFERENCE INDEX.

6-1. INTRODUCTION.

6-2. This section contains information about replacement parts. Table 6-1 lists parts in alphanumerical order of their reference designators and indicates the description and hp stock number of each part, together with any applicable notes. Table 6-2 lists parts in alpha-numerical order of their hp stock numbers and provides the following information on each part:

a. Description of the part (see list of abbreviations below).

b. Typical manufacturer of the part in a five-digit code; see list of manufacturers in Table 6-3.

c. Manufacturer's stock number.

d. Total quantity used in the instrument (TQ column).

6-3. Miscellaneous parts not indexed in Table 6-1 are listed at the end of the table.

6-4. DELETED

REFERENCE DESIGNATORS

A = assembly	F = fuse	MP = mechanical part	V = vacuum, tube, neon bulb, photocell, etc.
B = motor	FL = filter	P = plug	VR = voltage regulator
BT = battery	IC = integrated circuit	Q = transistor	W = cable
C = capacitor	J = jack	R = resistor	X = socket
CP = coupler	K = relay	RT = thermistor	Y = crystal
CR = diode	L = inductor	S = switch	Z = tuned cavity, network
DL = delay line	LS = loud speaker	T = transformer	
DS = device signaling (lamp)	M = meter	TB = terminal board	
E = misc electronic part	MK = microphone	TP = test point	

ABBREVIATIONS

A = amperes	H = henries	N/O = normally open	RMO = rack mount only
AFC = automatic frequency control	HDW = hardware	NPO = negative positive zero (zero temperature coefficient)	RMS = root-mean square
AMPL = amplifier	HEX = hexagonal		RWV = reverse working voltage
	HG = mercury	NPN = negative-positive-negative	S-B = slow-blow
BFO = beat frequency oscillator	HR = hour(s)	NRFR = not recommended for field replacement	SCR = screw
BE CU = beryllium copper	HZ = hertz	NSR = not separately replaceable	SE = selenium
BH = binder head			SECT = section(s)
BP = bandpass	IF = intermediate freq		SEMICON = semiconductor
BRS = brass	IMPG = impregnated		SI = silicon
BWO = backward wave oscillator	INCD = incandescent		
	INCL = include(s)		
	INS = insulation(ed)		
	INT = internal	OH = oval head	SIL = silver
CCW = counter-clockwise		OX = oxide	SL = slide
CER = ceramic			SPG = spring
CMO = cabinet mount only			SPL = special
COEF = coefficient	K = kilo		SST = stainless steel
COM = common			SR = split ring
COMP = composition	LH = left hand		STL = steel
COMPL = complete	LIN = linear taper	P = peak	
CONN = connector	LK WASH = lock washer	PC = printed circuit	
CP = cadmium plate	LOG = logarithmic taper	PF = picofarads = 10 ⁻¹² farads	
CRT = cathode-ray tube	LPF = low pass filter	PH BRZ = phosphor bronze	TA = tantalum
CW = clockwise		PHL = Phillips	TD = time delay
		PIV = peak inverse voltage	TGL = toggle
		PNP = positive-negative-positive	THD = thread
DEPC = deposited carbon	M = milli = 10 ⁻³	P/O = part of	TI = titanium
DR = drive	MEG = meg = 10 ⁶	POLY = polystyrene	TOL = tolerance
	MET FLM = metal film	PORC = porcelain	TRIM = trimmer
	MET OX = metallic oxide	POS = position(s)	TWT = traveling wave tube
ELECT = electrolytic	MFR = manufacturer	POT = potentiometer	
ENCAP = encapsulated	MHZ = mega hertz	PP = peak-to-peak	U = micro = 10 ⁻⁶
EXT = external	MINAT = miniature	PT = point	VAR = variable
F = farads	MOM = momentary	PWV = peak working voltage	VDCW = dc working volts
FH = flat head	MTG = mounting	RECT = rectifier	W/ = with
FIL H = fillister head	MY = "mylar"	RF = radio frequency	W = watts
FXD = fixed		RH = round head or right hand	WIV = working inverse voltage
G = giga (10 ⁹)	N = nano (10 ⁻⁹)		WW = wirewound
GE = germanium	N/C = normally closed		W/O = without
GL = glass	NE = neon		
GRD = ground(ed)	NI PL = nickel plate		

01194-13
 02293-1

Section VI
Table 6-1

Model 8406A

Table 6-1. Reference Designation Index

Reference Designation	hp Stock No.	Description #	Note
A1	08406-6001	BOARD ASSY., ETCHED CIRCUIT	
A1C1	0160-0174	C:FXD CER 0.47UF +80-20% 25VDCW	
A1C2	0160-0127	C:FXD CER 1WF 20% 25VDCW	
A1C3	0160-0134	C:FXD MICA 220PF 5% 300VDCW	
A1C4	0160-0194	C:FXD MY 0.01SUF 10%	
A1C5	0150-0050	C:FXD CER 1000PF 600 VDCW	
A1C6	0140-0145	C:FXD MICA 22 PF 5% 500 VDCW	
A1C7	0121-0127	C:VAR A1R 1.7-14PF	
A1CS	0150-0121	C:FXD CER 0.1UF +80X-20% 50VDCW	
A1C9	0150-0093	C:FXD CER 0.01UF +80-20% 100VDCW	
A1C10	0140-0192	C:FXD MICA 68PF 5% 300VDCW	
A1C11	0160-0179	C:FXD MICA 33PF 5% 300VDCW	
A1C12	0140-0192	C:FXD MICA 68PF 5% 300VDCW	
A1C13	0150-0096	C:FXD CER 0.05UF 100VDCW	
A1C14	0150-0121	C:FXD CER 0.1LUF +80%-20% 50VDCW	
A1C15	0140-0204	C:FXD MICA 47PF 5% NPO 500VDCW	
A1C16	0140-0232	C:FXD MICA 460PF 1% 300VDCW	
A1C17	0160-0178	C:FXD MICA 27PF 5% 300VDCW	
A1C18	0121-0127	C:VAR A1R 1.7-14PF	
A1C19	0140-0176	C:FXD MICA 100 PF 2% 300 VDCW	
A1C20	0150-0050	C:FXD CER 1000PF 600 VDCW	
A1C21	0140-0204	C:FXD MICA 47PF 5% NPO 500VDCW	
A1C22	0150-0093	C:FXD CER 0.01UF +80-20% 100VDCW	
A1C23	0150-0121	C:FXD CER 0.1UF +80%-20% 50VDCW	
A1C24	0160-0340	C:FXD MICA 600 PF 1% 300VDCW	
A1C25	0150-0050	C:FXD CER 1000PF 600 VDCW	
A1C26	0180-0119	C:FXD ELECT 1UF -10+100% 25VODC	
A1C27	0150-0050	C:FXD CER 1000PF 600 VDCW	
A1C28	0140-0209	C:FXD MICA 5PF 10% 500VDCW	
A1C29	0160-2197	C:FXD MICA 10PF 5%	
A1C30	0150-0050	C:FXD CER 1000PF 600 VDCW	
A1C31	0150-0050	C:FXD CER 1000PF 600 VDCW	
A1C32	0140-0209	C:FXD MICA 5PF 10% 500VDCW	
A1C33	0140-0232	C:FXD MICA 460PF 1% 300VDCW	
A1C34	0150-0050	C:FXD CER 100PF 600 VDCW	
A1C35	0180-0138	C:FXD ELECT 100UF -10+100% 40VDCW	
A1C36	0180-0059	C:FXD ELECT 10UF -10%+100% 25VDCW	
A1C37	0180-0059	C:FXD ELECT 10UF -10%+100% 25VDCW	
A1C38	0180-0059	C:FXD ELECT 10UF -10%+100% 25VDCW	
A1C39	0121-0127	C:VAR A1R 1.7-14PF	
A1C40	0150-0050	C:FXD CER 1000PF 600 VDCW	
A1C41	0160-2140	C:FXD CER 470 PF +80-2Y¼ 1000VDCW	
A1CR1	1901-0040	DIODE:SILICON 30 MA AT IV 30 PIV	
A1CR2	1912-0007	DIODE:TUNNEL EIA TYPE 1N3714	
A1CR3	1901-0026	DIODE:SILICON 200 PIV 0.5 AMP	
A1CR4	1901-0026	DIODE:SILICON 200 PIV 0.5 AMP	
A1CR5	1901-0025	DIODE:JUNCTION:5MA AT IV 100 PIV	
A1CR6	1901-0025	DIODE:JUNCTION:5MA AT IV 100 PIV	
A1CR7	1901-0025	DIODE:JUNCTION:5MA AT IV 100 PIV	
A1L1	9140-0131	COIL:FXD RF 10 MH	

See list of abbreviations in introduction to this section

Section VI
Table 6-1

Table 6-1. Reference Designation Index (Cont'd)

Reference Designation	hp Stock No.	Description #	Note
A1L2	9140-0131	COIL:FXD RF 10 MH	
A1L3	9140-0131	COIL:FXD RF 10 MH	
A1L4	9140-0181	COIL:FXD RF 22UH 5%	
A1L5	9140-0210	COIL:FXD RF 100 UH 5%	
A1L6	9140-0210	COIL:FXD RF 100 UH 5%	
A1L7	9140-0210	COIL:FXD RF 100 UH 5%	
A1LS	9140-0158	COIL:FXD 1.0UH 10%	
A1L9	9100-1612	COIL:FXD RF 0.33 UH 20%	
A1L10	9140-0210	COIL:FXD RF 100 UH 5%	
A1L11	9100-1613	COIL:FXD RF 0.47 UH 20%	
A1Q1	1854-0005	TRANSISTOR:2N708 NPN SILICON	
A1Q2	1854-0005	TRANSISTOR:2N708 NPN SILICON	
A1Q3	1850-0099	TRANSISTOR:GERMANIUM 2N964 PNP	
A1Q4	1854-0019	TRANSISTOR:SILICON NPN	
A1Q5	1854-0073	TRANSISTOR:SILICON NPN 2N3478	
A1Q6	1850-0062	TRANSISTOR:GERMANIUM PNP 2N404	
A1Q7	1854-0073	TRANSISTOR:SILICON NPN 2N3478	
A1Q8	1850-0062	TRANSISTOR:GERMANIUM PNP 2N404	
A1Q9	1850-0064	TRANSISTOR:GERMANIUM PNP 2N1183	
A1R1	0698-3156	R:FXD MET FLM 14.7K OHM 1% 1/8W	
A1R2	0757-0439	R:FXD MET FLM 6.81K OHM 1% 1/8W	
A1R3	0698-0082	R:FXD MET FLM 464 OHM 1% 1/8W	
A1R4	0698-3441	R:FXD MET FLM 215 OHM 1% 1/8W	
A1RS	0698-0083	R:FXD MET FLM 1960 OHM 1% 1/8W	
A1R6	0757-0465	R:FXD MET FLM 100K OHM 1% 1/8W	
A1R7	0698-0082	R:FXD MET FLM 464 OHM 1% 1/8W	
A1R8	0757-0280	R:FXD MET FLM 1.00K OHM 1% 1/8W	
A1R9	0698-3136	R:FXD MET FLM 17.8K OHM 1% 1/8W	
A1R10	0757-0439	R:FXD MET FLM 6.81K OHM 1% 1/8W	
A1R1L	0698-0082	R:FXD MET FLM 464 OHM 1% 1/8W	
A1R12	0698-3441	R:FXD MET FLM 215 OHM 1% 1/8W	
A1R13	0698-0084	R:FXD MET FLM 2150 OHM 1% 1/8W	
A1R14	0698-0084	R:FXD MET FLM 2150 OHM 1% 1/8W	
A1R15	0757-0280	R:FXD MET FLM 1.00K OHM 1% 1/8W	
A1R16	0757-1094	R:FXD MET FLM 1.47K OHM 1% 1/8W	
A1R17	0757-0401	R:FXD MET FLM 100 OHM 1% 1/8W	
A1R18	0698-3441	R:FXD MET FLM 215 OHM 1% 1/8W*	
A1R19	0757-0401	R:FXD MET FLM 100 OHM 1% 1/8W	
A1R20	0757-0441	R:FXD MET FLM 8.25K OHM 1% 1/8W	
A1R21	0698-3154	R:FXD MET FLM 4220 OHM 1% 1/8	
A1R22	0757-0417	R:FXD MET FLM 562 OHM 1% 1/8W	
A1R23	0698-3440	R:FXD MET FLM 196 OHM 15 1/8W	
A1R24	0698-3441	R:FXD MET FLM 215 OHM 1% 1/8W	
A1R25	0698-3430	R:FXD MET FLM 21.5 OHM 1% 1/8W	
A1R26	0698-3430	R:FXD MET FLM 21.5 OHM 1% 1/8W	
A1R27	0757-0346	R:FXD MET FLM 10.0 OHM 1% 1/8W	
A1R28	0698-0084	R:FXD MET FLM 2150 OHM 1% 1/8W	
A1R29	0698-0084	R:FXD MET FLM 2150 OHM 1% 1/8W	
A1R30	0757-0346	R:FXD MET FLM 10.0 OHM 1% 1/81	
A1R31	0698-3445	R:FXD MET FLM 348 OHM 1% 1/8W	
A1R32	0757-0416	R:FXD MET FLM 511 OHM 1% 1/8W	
A1T1	08406-6013	TRANSFORMER:RF(OSCILLATOR)	

See list of abbreviations in introduction to this section

Section VI
Table 6-1

Model 8406A

Table 6-1. Reference Designation Index

Reference Designation	hp Stock No.	Description #	Note
A1T2	08406-6014	TRANSFORMER:RF(AMPLIFIER)	
A1VR1	1902-0055	DIODE BREAKDOWN:SILICON 14.7V 10%	
A1XY1	1200-0028	SOCKET:CRYSTAL 2-CONTACT	
A1Y1	.0410-0013	CRYSTAL UNIT:QUARTZ 1000KC	
A1Y2	0410-0109	CRYSTAL:QUARTZ 10 MC	
A1Y3	0410-0108	CRYSTAL:QUARTZ 100 MC	
	5000-0011	CLIP:ELECTRICAL RETAINING	
C1	0150-0097	C:FXD CER 6800 PF 1000 VDCW	
C2	0150-0019	C:FXD CER 1000PF 20%	
C3	0150-0019-	C:FXD CER 1000PF 20%	
C4	0150-0097	C:FXD CER 6800 PF 1000 VDCW	
CR1	08406-6002 1901-0169 08551-2041 1150-0014 1250-0016	HOLDER ASSEMBLY, DIODE INCLUDES: SEMICON DEVICE:DIODE POST: DIODE CONTACT:OUTER N MALE CONNECTOR RING:LOCKING FOR TYPE N CONNECTOR	
	5020-0306 08406-2002 08406-2003	NUT:CONNECTOR BODY: DIODE HOLDER CENTER CONDUCTOR	
DS1	2140-0047	LAMP:GLOW 1/10W 0.8 MA 68K OHM	
F1	2110-0040	FUSE:CARTRIDGE 1/16 AMP SLOW BLOW	
J1	1250-0001	CONNECTOR:BNC	
J2	1250-0001	CONNECTOR:BNC	
J3	1251-0148	CONNECTOR:POWER 3 PIN MALE	
J4		NSR PART OF STEP DIODE ASSY.	
J5	08406-2004	CONNECTOR: PANEL	
L1	9170-0019	CORE:TOROID	
L2	9170-0019	CORE:TOROID	
P1		NSR PART OF ATTENUATOR ASSY	
R1	2100-0350	R:VAR COMP 1.SK OHM 20% LIN 1/2W	
R2	0687-6831	R:FXD COMP 68K OHM 10% 1/2W	
R3	2100-0350	R:VAR COMP 1500 OHM 20 LIN 1/2W	
S1	5101-0186	SWITCH:PUSHBUTTON(FREQUENCY)	
S2	5101-0033	SWITCH:SLIDE DPDT 115V-230V	
S3		NOT ASSIGNED	
S4		NSR PART OF R3	
T1	9100-1680	TRANSFORMER:POWER	
XF1	1400-0084	HOLDER:FUSE POST TYPE 3AG	
Z1	08406-6012 1460-0297 08491-6000 08491-2101 08491-2102	ATTENUATOR PAD ASSEMBLY INCLUDES: SPRING:COMPRESSION CARTRIDGE ASSEMBLY CONNECTOR:FEMALE Spacer, 2 ea.	

See list of abbreviations in introduction to this section

Table 6-1. Reference Designation Index (Cont'd)

Reference Designation	hp Stock No.	Description #	Note
	08742-0006	SPACER	
	08491-2002	BEAD	
	06491-4001	PIN, FEMALE	
	08491-2009	CONTACT, SLIDING	
		MISCELLANEOUS	
	08406-0003	BRACKET, BOTTOM COVER	
	08406-0004	BRACKET, RIGHT SUPPORT	
	08406-0005	BRACKET, LEFT SUPPORT	
	08406-0006	BRACKET, SWITCH	
	08406-6004	CABLE ASSY., COAX(ORANGE)	
	08406-6005	CABLE ASSY., COAX(RED)	
	08406-6006	CABLE ASSY., COAX(BROWN))	
	08406-6007	CABLE ASSY., COAX(BLACK))	
	08406-6009	CABLE ASSY., COAX(YELLOW)	
	08406-6010	CABLE ASSY., COAX(GREEN)	
	08406-6011	CABLE ASSY., COAX(BLUE)	
	8120-0078	CABLE ASSY:POWER	
	5040-0235	BASE:LAMPHOLDER	
	5040-0234	LAMPHOLDER	
	0370-0118	KNOB:GRAY PUSHBUTTON 11/16 IN DIA 1MC 10MC 100MC EXT TRIG	
	5000-3227	LABEL:PUSHBUTTON (1 MC)	
	5000-3228	LABEL:PUSHBUTTON(10 MC)	
	5000-3229	LABEL:PUSHBUTTON(100 MC)	
	5000-3248	LABEL:PUSHBUTTON(EXT. TRIG)	
	08406-0001	SUPPORT, LEFT	
	08406-0002	SUPPORT, RIGHT	
	0370-0103	KNOB:BLACK ROUND OUTPUT AMPLITUDE INTERPOLATION AMPLITUDE 1MC	

See list of abbreviations in introduction to this section

Table 6-1. Reference Designation Index (Cont'd)

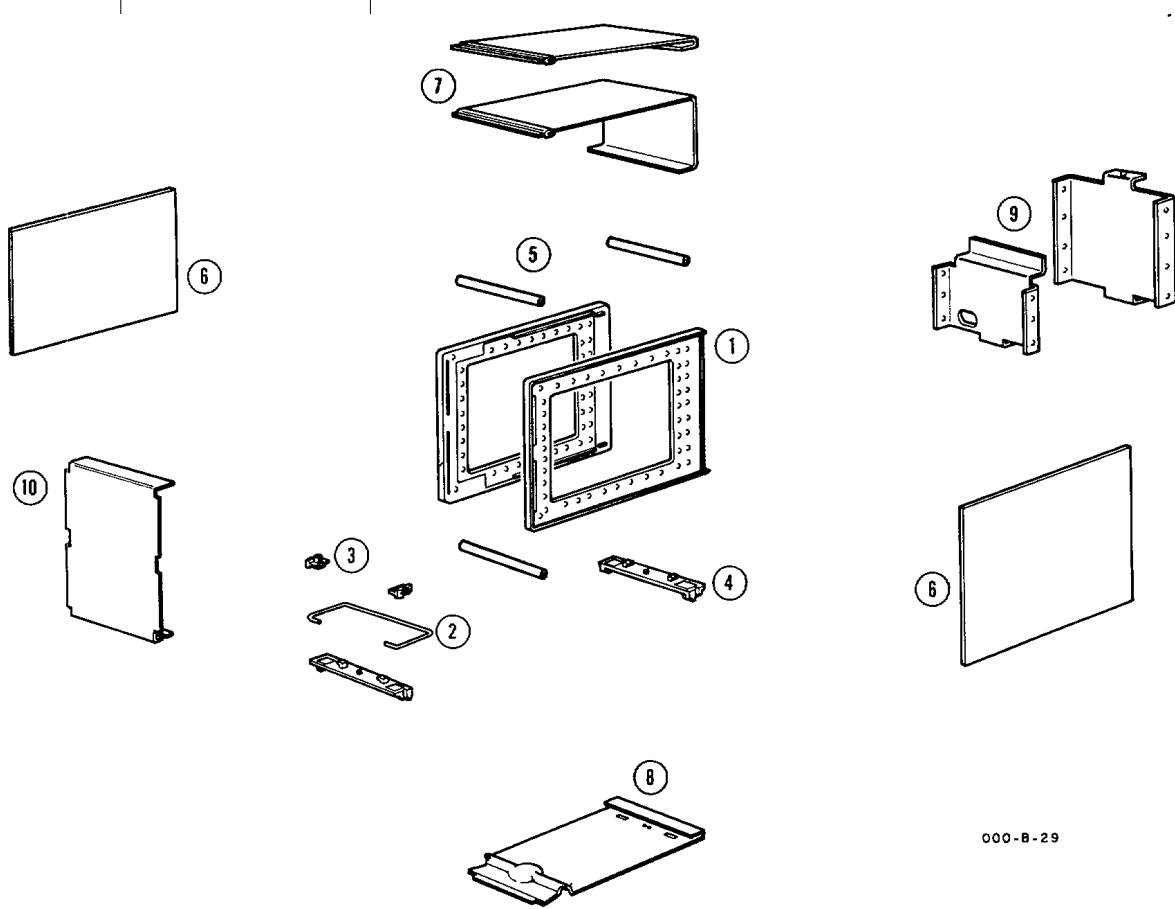
Reference Designation	hp Stock No.	Description #	Note
			
000-B-29			
MODULE SIZE 29			
<u>CABINET PARTS</u>			
1	5060-0703	FRAME ASSEMBLY	
2	1490-0031	STAND: TILT	
3	5040-0700	HINGE	
4	5060-0727	FOOT ASSEMBLY'	
5	5020-0700	SPACER	
6	5000-0703	COVER:SIDE	
7	5060-0709	COVER ASSEMBLY TOP	
	5060-0706	UNPERFORATED FULL RECESS	
	5060-0715	UNPERFORATED HALF RECESS	
	5060-0712	PERFORATED FULL RECESS	
	5000-0711	PERFORATED HALF RECESS	
8	5000-0711	COVER ASSEMBLY:BOTTOM	
	5000-0714	UNPERFORATED	
	5000-0714	PERFORATED	
9	SEE MAT'L. LIST	PANEL:REAR	
10	SEE MAT'L.. LIST	PANEL:FRONT	

See list of abbreviations in introduction to this section

Table 6-2. Replaceable Parts (Cont'd)

hp Stock No.	Description#	Mfr.	Mfr. Part No.	TQ
0121-0127	C:VAR AIR 1.7-14PF	28480	0121-0127	3
0140-0145	C:FXD MICA 22 PF 5% 500 VDCW	04062	RDM15C220J5C	1
0140-0176	C:FXD MICA 100 PF 2% 300 VDCW	04062	RDM15F101G3C	1
0140-0192	C:FXD MICA 68PF 5% 300VDCW	04062	RDM15E680J3C	2
0140-0204	C:FXD MICA 47PF 5% NPO 500VDCW	04062	RDM15E470J5C	2
0140-0209	C:FXD MICA 5PF 10% 500VDCW	04062	RDM15C050D5C	2
0140-0232	C:FXD MICA 460PF 1% 300VDCW	04062	RDM15F461F3C	2
0150-0019	C:FXD CER 1000PF 20%	72982	327005XUL0102M	2
0150-0050	C:FXD CER 1000PF 600 VDCW	84411	TYPE E	8
0150-0093	C:FXD CER 0.01UF +80-20% 100VDCW	91418	TA	2
0150-0096	C:FXD CER 0.05UF 100VDCW	91418	-TA	1
0150-0097	C:FXD CER 6800 PF 1000 VDCW	91418	B	2
0150-0121	C:FXD CER 0.1UF +80%-20% 50VDCW	56289	5050A	3
0160-0127	C:FXD CER 1UF 204 25VDCW	56289	5013	1
0160-0134	C:FXD MICA 220PF 5% 300VDCW	14655	RDM15F221J3C	1
0160-0174	C:FXD CER 0.47UF +80-20% 25VDCW	56289	5C11A	1
0160-0178	C:FXD MICA 27PF 5% 300VDCW	04062	RDM15E270J3S	1
0160-0179	C:FXD MICA 33PF 5% 300VDCW	04062	ROM15E330J3S	1
0160-0194	C:FXD MY 0.015UF 10%	28480	0160-0194	1
0160-0340	C:FXD MICA 600 PF 1% 300VDCW	04062	RDM15F601F3C	1
0160-2140	C:FXD CER 470 PF +80-20% 1000VDCW	91418	TYPE B	1
0160-2197	C:FXD MICA 10PF 5%	28480	0160-2197	1
0180-0059	C:FXD ELECT 10UF -10%+100% 25VDCW	56289	30D106G025BB4	5
0180-0119	C:FXD ELECT 1UF -10+100% 25VDCW	56289	30D105G025AA4	1
0180-0138	C:FXD ELECT 100UF -10+100% 40VDCW	56289	036254	1
0570-0103	KNOB:BLACK ROUND	28480	0370-0103	2
0370-0118	KNOB:GRAY PUSHBUTTON 11/16" DIA	28480	0370-0118	4
0410-0013	CRYSTAL UNIT:QUARTZ 1000KC	28480	0410-0013	1
0410-0108	CRYSTAL:QUARTZ 100 MC	28480	0410-0108	1
0410-0109	CRYSTAL:QUARTZ 10 MC	28480	0410-0109	1
0687-68351	R:FXD COMP 68K OHM 10% 1/2W	01121	EB-6831	1
0698-0082	R:FXD MET FLM 464 OHM 1% 1/8W	28480	0698-0082	3
0698-0083	R:FXD MET FLM 1960 OHM 1% 1/8W	28480	0698-0083	1
0698-0084	R:FXD MET FLM 2150 OHM 1% 1/8W	28480	0698-0084	4
0698-3136	R:FXD MET FLM 17.8KOHM 1% 1/8W	28480	0698-3136	1
0698-3154	R:FXD MET FLM 4220 OHM 1% 1/8W	28480	0698-3154	1
0698-3156	R:FXD MET FLM 14.7KOHM 1% 1/8W	28480	0698-3156	1
0698-3430	R:FXD MET FLM 21.5 OHM 1% 1/8W	28480	0698-5430	2
0698-3440	R:FXD MET FLM 196 OHM 1% 1/8W	28480	0698-3440	1
0698-3441	R:FXD MET FLM 215 OHM 1% 1/8W	28480	0698-3441	4
0698-3445	R:FXD MET FLM 348 OHM 1% 1/8W	28480	0698-3445	1
0757-0280	R:FXD MET FLM 1.0KOHM 1% 1/8W	28480	0757-0280	2
0757-0346	R:FXD MET FLM 10.0 OHM 1% 1/8W	28480	0757-0346	2
0757-0LwUo	R:FXD MET FLM 100 OHM 1% 1/8W	28480	0757-0401	2
0757-0416	R:FXD MET FLM 511 OHM 1% 1/8W	28480	0757-0416	1
0757- 0417	R:FXD MET FLM 562 OHM 1% 1/8W	28480	0757-0417	1
0757- 0439	R:FXD MET FLM 6.81K OHM 1% 1/8W	28480	0757-0439	2
0757-0441	R:FXD MET FLM 8.25KOHM 1% 1/8W	28480	0757-0441	1
0757-1094	R:FXD MET FLM 1.47K OHM 1% 1/8W	28480	0757-1094	1
1200-0028	SOCKET:CRYSTAL 2-CONTACT	91662	430 BC	1
1250-0014	CONTACT:OUTER N MALE CONNECTOR	28480	1250-0014	1
1250-0016	RING:LOCKING FOR TYPE N CONNECTOR	28480	1250-0016	1
1250-0001	CONNECTOR:BNC	28480	1250-0001	2
1251-0148	CONNECTOR:POWER 3 PIN MALE	60427	H-1061-2	1
1400-0064	HOLDER:FUSE POST TYPE 3AG	75915	342014	1

See list of abbreviations in introduction to this section

Section VI
Table 6-2

Model 8406A

Table 6-2. Replaceable Parts (Cont'd)

hp Stock No.	Description#	Mfr.	Mfr. Part No.	TQ
1460-0297	SPRING:COMPRESSION	28480	1460-0297	2
1490-0031	STAND:TILT	28480	1490-0031	1
1850-0062	TRANSISTOR:GERMANIUM PNP 2N404	28480	1850-0062	2
1850-0064	TRANSISTOR:GERMANIUM PNP 2N1183	02735	2N1183	1
1850-0099	TRANSISTOR:GERMANIUM 2N964 PNP	04713	2N964	1
1854-0005	TRANSISTOR:2N708 NPN SILICON	07263	2N708	2
1854-0019	TRANSISTOR:SILICON NPN	28480	1854-0019	1
1854-0073	TRANSISTOR:SILICON NPN 2N3478	93332	2N3478	2
1901-0025	DIODE,JUNCTION:5MA AT 1V 100 PIV	28480	1901-0025	3
1901-0026	DIODE:SILICON 200 PIV 0.5 AMP	28480	1901-0026	2
1901-0040	DIODE:SILICON 30 MA AT 1V 30 PIV	28480	1901-0040	1
1901-0169	SEMICON DEVICE:DIODE	28480	1901-0169	1
1902-0055	DIODE BREAKDOWN:SILICON 14.7V 10%	28480	1902-0055	1
1912-0007	DIODE:TUNNEL EIA TYPE 1N3714	03508	1N3714 SPEC	1
2100-0350	R:VAR COMP 1500 OHM 20% LIN 1/2W	28480	2100-0350	1
2100-0350	R:VAR COMP 1.5K OHM 20% LIN 1/2W	28480	2100-0350	1
2110-0040	FUSE:CARTRIDGE 1/16 AMP SLOW BLOW	75915	313.062	1
2140-0047	LAMP:GLOW 1/10W 0.8 MA 68K OHM	24455	A1C	1
3101-0033	SWITCH:SLIDE DPDT	42190	4633	1
3101-0186	SWITCH:PUSHBUTTON(FREQUENCY)	28480	3101-0186	1
5000-0011	CLIP:ELECTRICAL RETAINING	28480	5000-0011	1
5000-3227	LABEL:PUSHBUTTON (1 MC)	28480	5000-3227	1
5000-3228	LABEL:PUSHBUTTON(10 MC)	28480	5000-3228	1
5000-3229	LABEL:PUSHBUTTON(100 MC)	28480	5000-3229	1
5000-3248	LABEL:PUSHBUTTON(EXT. TRIG)	28480	5000-3248	1
5020-0306	NUT:CONNECTOR	28480	5020-0306	1
5040-0234	LAMPHOLDER:(FOR 4 LAMPS)	28480	5040-0234	1
5040-0235	BASE:LAMPHOLDER	28480	5040-0235	1
5040-0700	HINGE	28480	5040-0700	1
5060-0703	COVER:6 X 11 SIDE	28480	5060-0703	1
5060-0709	COVER ASSY:TOP 5 X 11 SM	28480	5060-0709	1
8120-0078	CABLE ASSY:POWER	70903	KH-4147	1
9100-1612	COIL:FXD RF 0.33 UH 20%	28480	9100-1612	1
9100-1678	TRANSFORMER:OSCILLATOR	28480	9100-1678	1
9100-1679	TRANSFORMER:RF AMPL	28480	9100-1679	1
9100-1613	COIL:FXD RF 0.47 UH 20%	28480	9100-1613	1
9100-1680	TRANSFORMER:POWER	28480	9100-1680	1
9140-0131	COIL:FXD RF 10 MH	28480	9140-0131	3
9140-0158	COIL:FXD 1.0UH 10%	99800	1025-20	1
9140-0181	COIL:FXD RF 22UH 5%	78526	12201M	1
9140-0210	COIL:FXD RF 100 UH 5%	28480	9140-0210	4
9170-0019	CORE:TOROID	72656	CF104 Q-1	2
08406-0001	SUPPORT, LEFT	28480	08406-0001	1
08406-0002	SUPPORT, RIGHT	28480	08406-0002	1
08406-0003	BRACKET, BOTTOM COVER	28480	08406-0003	1
08406-0004	BRACKET, RIGHT SUPPORT	28480	08406-0004	1
08406-0005	BRACKET, LEFT SUPPORT	28480	08406-0005	1
08406-0006	BRACKET, SWITCH	28480	08406-0006	1
08406-0007	COVER, TOP	28480	08406-0007	1
08406-0008	COVER, BOTTOM	28480	08406-0008	1
08406-0009	PANEL, REAR	28480	08406-0009	1

See list of abbreviations in introduction to this section

Table 6-2. Replaceable Parts (Cont'd)

hp Stock No.	Description#	Mfr.	Mfr. Part No.	TQ
08406-0010	PANEL, FRONT	28480	08406-0010	1
08406-0011	CHASSIS	28480	08406-0011	1
08406-2002	BODY, DIODE HOLDER	28480	08406-2002	1
08406-2003	CENTER CONDUCTOR	28480	08406-2003	1
08406-2004	CONNECTOR, PANEL	28480	08406-2004	1
08406-2104	CONNECTOR:PANEL	28480	08406-2104	1
08406-6001	BOARD ASSY., ETCHED CIRCUIT	28480	08406-6001	1
08406-6002	HOLDER ASSEMBLY, DIODE	28480	08406-6002	1
08406-6004	CABLE ASSY., COAX(ORANGE)	28480	08406-6004	1
08406-6005	CABLE ASSY., COAX(RED)	28480	08406-6005	1
08406-6006	CABLE ASSY., COAX(BROWN))	28480	08406-6006	1
08406-6007	CABLE ASSY., COAX(BLACK))	28480	08406-6007	1
08406-6009	CABLE ASSY., COAX(YELLOW)	28480	08406-6009	1
08406-6010	CABLE ASSY., COAX(GREEN)	28480	08406-6010	1
08406-6011	CABLE ASSY., COAX(BLUE)	28480	08406-6011	1
08406-6012	ATTENUATOR PAD ASSEMBLY	28480	08406-6012	1
08491-2101	CONNECTOR:FEMALE	28480	08491-2101	1
08491-2002	BEAD	28480	08491-2002	2
08491-2004	PIN, FEMALE	28480	08491-2004	2
08491-2005	CONTACT, SLIDING	28480	08491-2005	2
08491-6000	CARTRIDGE ASSEMBLY	28480	08491-6000	1
08551-2041	POST:DIODE	28480	08551-2041	1
08742-0006	SPACER	28480	08742-0006	1
5000-0703	COVER:SIDE 6X11 SM	28480	5000-0703	2
5000-0711	COVER:BOTTOM 5X11 SM	28480	5000-0711	1
5060-0727	FOOT ASSY: 1/3 MOD	28480	5060-0727	1
08406-6013	TRANSFORMER: RF (Oscillator)			
08406-6014	TRANSFORMER: RF: (Amplifier)			
	Add to ATTENUATOR PAD ASS'Y: SPACER		08491-2102	2

See list of abbreviations in introduction to this section

TABLE 6-3.
CODE LIST OF MANUFACTURERS

The following code numbers are from the Federal Supply Code for Manufacturers Cataloging Handbooks H4-1 (Name to Code) and H4-2 (Code to Name) and their latest supplements. The date of revision and the date of the supplements used appear at the bottom of each page. Alphabetical codes have been arbitrarily assigned to suppliers not appearing in the H4 Handbooks.

Code No.	Manufacturer	Address	Code No.	Manufacturer	Address	Code No.	Manufacturer	Address
00000	U. S. A. Common	Any supplier of U. S.	05397	Union Carbide Corp., Linde Div., Kemet Dept.	Cleveland, Ohio	11242	Bay State Electronics Corp.	Waltham, Mass.
00136	McCoy Electronics	Mount Holly Springs, Pa.	05593	Illuminetric Engineering Co.	Sunnyvale, Calif.	11312	Teledyne Inc., Microwave Div.	Palo Alto, Calif.
00213	Sage Electronics Corp.	Rochester, N. Y.	05616	Cosmo Plastic	Cleveland, Ohio	11534	Duncan Electronics Inc.	Costa Mesa, Calif.
00287	Cemco Inc.	Danielson, Conn.	05624	(C/O Electrical Spec. Co.) Barber Colman Co.	Rockford, Ill.	11711	General Instrument Corp., Semiconductor Div., Products Group	Newark, N. J.
00334	Humidia	Colton, Calif.	05729	Metro-Tel Corp.	Westbury, N. Y.	11717	Imperial Electronic, Inc.	Buena Park, Calif.
00348	Microtron Co., Inc.	Valley Stream, N. Y.	05783	Stewart Engineering Co.	Santa Cruz, Calif.	11870	Melabs, Inc.	Palo Alto, Calif.
00373	Garlock Inc., Electronics Products Div.	Camden, N. J.	05820	Wakefield Engineering Inc.	Wakefield, Mass.	12136	Philadelph a Handle Co.	Camden, N. J.
00656	Aerovox Corp.	New Bedford, Mass.	06004	Bassick Co., The	Bridgeport, Conn.	12361	Grove Mfg. Co., Inc.	Shady Grove, Pa.
00779	Amp. Inc.	Harrisburg, Pa.	06090	Raychem Corp.	Redwood City, Calif.	12574	Gulton Ind. Inc., CG Elect. Div.	Albuquerque, N. M.
00781	Aircraft Radio Corp.	Boonton, N. J.	06175	Bausch and Lomb Optical Co.	Rochester, N. Y.	12697	Clarostat Mfg. Co.	Dover, N. H.
00815	Northern Engineering Laboratories, Inc.	Burlington, Wis.	06402	E. T. A. Products Co. of America	Chicago, Ill.	12728	Elmar Filter Corp.	W. Haven, Conn.
00853	Sangamo Electric Co., Pickens Div.	Pickens, S. C.	06440	Amalton Electronic Hardware Co., Inc.	New Rochelle, N. Y.	12859	Nippon Electric Co., Ltd.	Tokyo, Japan
00866	Goe Engineering Co.	Los Angeles, Calif.	06555	Beede Electrical Instrument Co., Inc.	Penacook, N. H.	12881	Metex Electronics Corp.	Clark, N. J.
00891	Carl E. Holmes Corp.	Los Angeles, Calif.	06666	General Devices Co., Inc.	Indianapolis, Ind.	12930	Delta Semiconductor Inc.	Newport Beach, Calif.
30929	Microlab Inc.	Livingston, N. J.	06751	Semcor Div. Components Inc.	Phoenix, Ariz.	12954	Dickson Electronics Corp.	Scottsdale, Arizona
01002	General Electric Co. Capacitor Dept.	Hudson Falls, N. Y.	06812	Torrington Mfg. Co., West Div.	Van Nuys, Calif.	13103	Thermolloy	Dallas, Texas
01009	Alden Products Co.	Brockton, Mass.	06980	Varian Assoc. Eimac Div.	San Carlos, Calif.	13356	Telefunken (GmbH)	Hanover, Germany
01121	Allen Bradley Co.	Milwaukee, Wis.	07088	Kelvin Electric Co.	Van Nuys, Calif.	13835	Micland-Wright Div. of Pacific Industries, Inc.	Kansas City, Kansas
01255	Litton Industries, Inc.	Beverly Hills, Calif.	07126	Digitalan Co.	Pasadena, Calif.	14099	Sem-Tech	Newbury Park, Calif.
01281	TRW Semiconductors, Inc.	Lawndale, Calif.	07137	Transistor Electronics Corp.	Minneapolis, Minn.	14193	Calil. Resistor Corp.	San Jose, Calif.
01295	Texas Instruments, Inc., Transistor Products Div.	Dallas, Texas	07138	Westinghouse Electric Corp. Electronic Tube Div.	Elmira, N. Y.	14298	American Components, Inc	Conshohocken, Pa.
01349	The Alliance Mfg. Co.	Alliance, Ohio	07149	Frimohn Corp.	New York, N. Y.	14433	ITT Semiconductor, A Div. of Int. Telephone & Telegraph Corp.	West Palm Beach, Fla.
01589	Pacific Relays, Inc.	Van Nuys, Calif.	07233	Cinch-Graphik Co.	City of Industry, Calif.	14493	Hewlett-Packard Company	Love and, Colo.
01930	Amerock Corp.	Rockford, Ill.	07251	Avnet Corp.	Culver City, Calif.	14655	Cornell Dublier Electric Corp.	Newark, N. J.
01961	Pulse Engineering Co.	Santa Clara, Calif.	07263	Fairchild Camera & Inst. Corp. Semiconductor Div.	Mountain View, Calif.	14674	Corning Glass Works	Corning, N. Y.
02114	Ferroxcube Corp. of America	Saugerties, N. Y.	07322	Minnesota Rubber Co.	Minneapolis, Minn.	14752	Electro Cube Inc.	So. Pasadena, Calif.
02116	Wheelock Signals, Inc.	Long Branch, N. J.	07387	Birtcher Corp., The	Monterey Park, Calif.	14960	Williams Mfg. Co.	San Jose, Calif.
02286	Cole Rubber and Plastics Inc.	Sunnyvale, Calif.	07397	Sylvania Elect. Prod. Inc., Mt. View Operations	Mountain View, Calif.	15203	Webster Electronics Co.	New York, N. Y.
02660	Amphenol-Borg Electronics Corp.	Chicago, Ill.	07700	Technical Wire Products Inc.	Cranford, N. J.	15287	Scionics Corp.	Northridge, Calif.
02735	Radio Corp. of America, Semiconductor and Materials Div.	Somerville, N. J.	07910	Continental Device Corp.	Hawthorne, Calif.	15291	Adjustable Bushing Co.	N. Hollywood, Calif.
02771	Vocaline Co. of America, Inc.	Old Saybrook, Conn.	07933	Raytheon Mfg. Co., Semiconductor Div.	Mountain View, Calif.	15558	Vicron Electronics	Garden City, Long Island, N. Y.
02777	Hopkins Engineering Co.	San Fernando, Calif.	07980	Hewlett-Packard Co., Boonton Radio Div.	Rockaway, N. J.	15566	Anorobe Inst. Corp.	Lynbrook, N. Y.
03538	G. E. Semiconductor Prod. Dept.	Syracuse, N. Y.	08145	U. S. Engineering Co.	Los Angeles, Calif.	15631	Cabletronics	Costa Mesa, Calif.
03705	Apex Machine & Tool Co.	Clayton, Ohio	08289	Blinn, Debert Co.	Pomona, Calif.	15772	Twentieth Century Coil Spring Co.	San Jose, Calif.
03797	Eldema Corp.	Compton, Calif.	08358	Burgess Battery Co.	Niagara Falls, Ontario, Canada	15818	Amelco Inc.	MT. View, Calif.
03877	Transiltron Electric Corp.	Wakfield, Mass.	08524	Deutsch Fastener Corp.	Los Angeles, Calif.	15939	Oaven Div. Thomas A. Edison Ind. McGraw-Edison Co.	Long Island City, N. Y.
03638	Pyrofilm Resistor Co., Inc.	Cedar Knolls, N. J.	08664	Bristol Co., The	Waterbury, Conn.	16037	Spruce Pine Mica Co.	Spruce Pine, N. C.
03654	Singer Co., Diehl Div.	Sumerville, N. J.	08717	Sloan Company	Sun Valley, Calif.	16179	Omni-Spectra Inc.	Detroit, Ill.
04009	Arrow, Hart and Hegeman Elect. Co.	Hartford, Conn.	08718	ITT Cannon Electric, Inc.	Phoenix, Arizona	16352	Compute Diode Corp.	Lodi, N. J.
04013	Taurus Corp.	Lambertville, N. J.	08792	CBS Electronics Semiconductor Operations, Div. of C. B. S. Inc.	Lowell, Mass.	16688	Ideal Prec. Meter Co., Inc.	Brooklyn, N. Y.
04222	Hi-Q Division of Aerovox	Myrtle Beach, S. C.	08924	Mel-Rain	Indianapolis, Ind.	16758	DeLco Radio Div. of G. M. Corp.	Kokomo, Ind.
04354	Precision Paper Tube Co.	Chicago, Ill.	09026	Babcock Relays Div.	Costa Mesa, Calif.	17109	Thermonetics Inc.	Caroga Park, Calif.
04404	Oymec Division of Hewlett-Packard Co.	Palo Alto, Calif.	09134	Texas Capacitor Co.	Houston, Texas	17474	T-axex Company	Mountain View, Calif.
04651	Sylvania Electric Products, Microwave Device Div.	Mountain View, Calif.	09145	Atomh Electronics	Sun Valley, Calif.	17675	Harlin Metal Products Corp	Akron, Ohio
04713	Motorola, Inc., Semiconductor Prod. Div.	Phoenix, Arizona	09250	Electro Assemblies, Inc.	Chicago, Ill.	17745	Angstrom Prec. Inc.	No. Hollywood, Calif.
04732	Filttron Co., Inc. Western Div.	Culver City, Calif.	09569	Mallory Battery Co. of Canada, Ltd.	Toronto, Ontario, Canada	18042	Power Design Pacific Inc.	Palo Alto, Calif.
04773	Automatic Electric Co.	Northlake, Ill.	10214	General Transistor Western Corp.	Los Angeles, Calif.	18083	Clevite Corp., Semiconductor Div.	Palo Alto, Calif.
04796	Sequoia Wire Co.	Redwood City, Calif.	10411	Ti-Tal, Inc.	Berkeley, Calif.	18476	Ty-Car Mfg. Co., Inc.	Holliston, Mass.
04811	Precision Coil Spring Co.	El Monte, Calif.	10646	Carborundum Co.	Niagara Falls, N. Y.	18486	TRW Elect. Compo. Div.	Des Plaines, Ill.
04870	P. M. Moloi Company	Westchester, Ill.	11236	CTS of Berne, Inc.	Berne, Ind.	18533	Curtis Instrument, Inc.	MT. Kisco, N. Y.
04919	Component Mfg. Service Co.	W. Bridgewater, Mass.	11237	Chicago Telephone of California, Inc.	So. Pasadena, Calif.	18673	E. I. DuPont and Co., Inc.	Wilmington, Del.
05006	Twentieth Century Plastics, Inc.	Los Angeles, Calif.				18511	Duraat Mfg. Co.	Milwaukee, Wis.
05277	Westinghouse Electric Corp. Semi-Conductor Dept.	Youngwood, Pa.				19315	Bendix Corp., The Eclipse-Poinee' Div.	Teterboro, N. J.
05347	Ultronix, Inc.	San Mateo, Calif.				19500	Thomas A. Edison Industries, Div. of McGraw-Edison Co.	West Orange, N. J.

00015-43
Revised: May, 1967

From: FSC Handbook Supplements
H4-1 Dated AUGUST 1966
H4-2 Dated NOV 1962

02293-2

TABLE 6-3.
CODE LIST OF MANUFACTURERS (Cont'd)

Code No.	Manufacturer	Address	Code No.	Manufacturer	Address	Code No.	Manufacturer	Address
21335	Fafnir Bearing Co., The	New Britain, Conn.	71450	CTS Corp.	Elkhart, Ind.	77075	Pacific Metals Co.	San Francisco, Calif.
21520	Fansteel Metallurgical Corp.	N. Chicago, Ill.	71468	ITT Cannon Electric Inc.	Los Angeles, Calif.	77221	Phanostran Instrument and Electronic Co.	South Pasadena, Calif.
23783	British Radio Electronics Ltd.	Washington, D. C.	71471	Cinema, Div. Aerovox Corp.	Burbank, Calif.	77252	Philadelphia Steel and Wire Corp.	Philadelphia, Pa.
24455	G. E. Lamp Division	Nela Park, Cleveland, Ohio	71482	C. P. Clare & Co.	Chicago, Ill.	77342	American Machine & Foundry Co. Potter & Brumfield Div.	Princeton, Ind.
24655	General Radio Co.	West Concord, Mass.	71590	Centralab Div. of Globe Union Inc.	Milwaukee, Wis.	77630	TRW Electronic Components Div.	Camden, N. J.
26365	Gries Reproducer Corp.	New Rochelle, N. Y.	71616	Commercial Plastics Co.	Chicago, Ill.	77638	General Instrument Corp., Rectifier Div.	Brooklyn, N. Y.
26462	Globet File Co. of America, Inc.	Carlstadt, N. J.	71700	Cornish Wire Co., The	New York, N. Y.	77764	Resistance Products Co.	Harrisburg, Pa.
26992	Hamilton Watch Co.	Lancaster, Pa.	71707	Colo Coil Co., Inc.	Providence, R. I.	77969	Rubbercraft Corp. of Calif.	Torrance, Calif.
28480	Hewlett-Packard Co.	Palo Alto, Calif.	71744	Chicago Miniature Lamp Works	Chicago, Ill.	78189	Shakeproof Division of Illinois Tool Works	Elgin, Ill.
28520	Heyman Mfg. Co.	Kenilworth, N. J.	71753	A. O. Smith Corp., Crowley Div.	West Orange, N. J.	78283	Signal Indicator Corp.	New York, N. Y.
33173	G. E. Receiving Tube Dept.	Owensboro, Ky.	71785	Cinch Mfg. Co., Howard B. Jones Div.	Chicago, Ill.	78290	Struthers-Dunn Inc.	Pittman, N. J.
35343	Leclorohm Inc.	Chicago, Ill.	71984	Dow Corning Corp.	Midland, Mich.	78452	Thompson-Bremer & Co.	Chicago, Ill.
36196	Stanwyck Coil Products Ltd.	Hawkesbury, Ontario, Canada	72136	Electro Motive Mfg. Co., Inc.	Williamantic, Conn.	78471	Tilley Mfg. Co.	San Francisco, Calif.
36287	Cunningham, W. H. & Hill, Ltd.	Toronto Ontario, Canada	72354	John E. Fast Co., Div. Victoreen Instr. Co.	Chicago, Ill.	78488	Stackpole Carbon Co.	St. Marys, Pa.
37942	P. R. Mallory & Co. Inc.	Indianapolis, Ind.	72619	Dialight Corp.	Brooklyn, N. Y.	78493	Standard Thomson Corp.	Waltham, Mass.
39543	Mechanical Industries Prod. Co.	Akron, Ohio	72656	Indiana General Corp., Electronics Div.	Keasby, N. J.	78553	Tinnerman Products, Inc.	Cleveland, Ohio
40920	Miniature Precision Bearings, Inc.	Keene, N. H.	72699	General Instrument Corp., Cap. Div.	Newark, N. J.	78790	Transformer Engineers	San Gabriel, Calif.
42190	Muter Co.	Chicago, Ill.	72765	Drake Mfg. Co.	Chicago, Ill.	78947	Ucinite Co.	Newtonville, Mass.
43990	C. A. Norgren Co.	Englewood, Colo.	72825	Hugh H. Eby Inc.	Philadelphia, Pa.	79136	Waides Kobinor Inc.	Long Island City, N. Y.
44655	Ohmite Mfg. Co.	Skokie, Ill.	72928	Gudeman Co.	Chicago, Ill.	79142	Veeder Root, Inc.	Hartford, Conn.
46384	Penn Eng. & Mfg. Corp.	Doylestown, Pa.	72964	Robert M. Hadley Co.	Los Angeles, Calif.	79251	Wenco Mfg. Co.	Chicago, Ill.
47904	Polaroid Corp.	Cambridge, Mass.	72982	Erie Technological Products, Inc.	Erie, Pa.	79727	Continental-Wirt Electronics Corp.	Philadelphia, Pa.
48620	Precision Thermometer & Inst. Co.	Southampton, Pa.	73061	Hansen Mfg. Co., Inc.	Princeton, Ind.	79963	Zierick Mfg. Corp.	New Rochelle, N. Y.
49956	Microwave & Power Tube Div.	Waltham, Mass.	73076	H. M. Harper Co.	Chicago, Ill.	80031	Mepco Division of Sessions Clock Co.	Morristown, N. J.
52090	Rowan Controller Co.	Westminster, Md.	73138	Helipot Div. of Beckman Inst., Inc.	Fullerton, Calif.	80120	Schnitzer Alloy Products Co.	Elizabeth, N. J.
52983	Sanborn Company	Waltham, Mass.	73293	Hughes Products Division of Hughes Aircraft Co.	Newport Beach, Calif.	80131	Electronic Industries Association. Any brand Tube meeting EIA Standards-Washington, DC.	Washington, D. C.
54294	Shaffcross Mfg. Co.	Selma, N. C.	73445	Amperex Electronic Co., Div. of North American Phillips Co., Inc.	Hicksville, N. Y.	80207	Unimax Switch, Div. Maxon Electronics Corp.	Wallingford, Conn.
55026	Simpson Electric Co.	Chicago, Ill.	73506	Bradley Semiconductor Corp.	New Haven, Conn.	80223	United Transformer Corp.	New York, N. Y.
55933	Sonotone Corp.	Elmsford, N. Y.	73559	Carling Electric, Inc.	Hartford, Conn.	80248	Oxford Electric Corp.	Chicago, Ill.
55938	Raytheon Co. Commercial Apparatus & Systems Div.	So. Norwalk, Conn.	73586	Circle F Mfg. Co.	Trenton, N. J.	80294	Bourns Inc.	Riverside, Calif.
56137	Spaulding Fibre Co., Inc.	Tonawanda, N. Y.	73682	George K. Garrett Co., Div. MSL Industries Inc.	Philadelphia, Pa.	80411	Acro Div. of Robertshaw Controls Co.	Columbus, Ohio
56289	Sprague Electric Co.	North Adams, Mass.	73734	Federal Screw Products Inc.	Chicago, Ill.	80486	All Star Products Inc.	Defiance, Ohio
59446	Telex, Inc.	St. Paul, Minn.	73743	Fischer Special Mfg. Co.	Cincinnati, Ohio	80509	Avery Adhesive Label Corp.	Montevia, Calif.
59730	Thomas & Betts Co.	Elizabeth, N. J.	73793	General Industries Co., The	Elyria, Ohio	80583	Hammarlund Co., Inc.	New York, N. Y.
60741	Triplet Electrical Inst. Co.	Bluffton, Ohio	73846	Goshen Stamping & Tool Co.	Goshen, Ind.	80640	Stevens, Arnold, Co., Inc.	Boston, Mass.
61775	Union Switch and Signal, Div. of Westinghouse Air Brake Co.	Pittsburgh, Pa.	73899	JFD Electronics Corp.	Brooklyn, N. Y.	81030	International Instruments Inc.	Orange, Conn.
62119	Universal Electric Co.	Owosso, Mich.	73905	Jennings Radio Mfg. Corp.	San Jose, Calif.	81073	Grayhill Co.	LaGrange, Ill.
63743	Ward-Leonard Electric Co.	Mt. Vernon, N. Y.	74276	Signalite Inc.	Neptune, N. J.	81095	Triad Transformer Corp.	Venice, Calif.
64959	Western Electric Co., Inc.	New York, N. Y.	74455	J. H. Winns, and Sons	Winchester, Mass.	81312	Winchester Elec. Div. Litton Ind., Inc.	Oakville, Conn.
65092	Weston Inst. Inc. Weston-Newark	Newark, N. J.	74861	Industrial Condenser Corp.	Chicago, Ill.	81349	Military Specification	El Segundo, Calif.
66295	Witteck Mfg. Co.	Chicago, Ill.	74868	R. F. Products Division of Amphenol-Borg Electronics Corp.	Danbury, Conn.	81483	International Rectifier Corp.	El Segundo, Calif.
66346	Revere Wollansak Div. Minn. Mining & Mfg. Co.	St. Paul, Minn.	74970	E. F. Johnson Co.	Waseca, Minn.	81541	Airpax Electronics, Inc.	Cambridge, Mass.
70276	Allen Mfg. Co.	Hartford, Conn.	75042	International Resistance Co.	Philadelphia, Pa.	81860	Barry Controls, Div. Barry Wright Corp.	Waterstown, Mass.
70309	Allied Control	New York, N. Y.	75378	CTS Knights Inc.	Sandwich, Ill.	82042	Carter Precision Electric Co.	Skokie, Ill.
70318	Allmetal Screw Product Co., Inc.	Garden City, N. Y.	75382	Kulka Electric Corporation	Mt. Vernon, N. Y.	82047	Sperli Faraday Inc., Copper Hewlett Electric Div.	Hoboken, N. J.
70485	Allantic India Rubber Works, Inc.	Chicago, Ill.	75818	Lenz Electric Mfg. Co.	Chicago, Ill.	82142	Jeffers Electronics Division of Speer Carbon Co.	Du Bois, Pa.
70563	Amperite Co., Inc.	Union City, N. J.	75915	Littelfuse, Inc.	Des Plaines, Ill.	82170	Fairchild Camera & Inst. Corp., Defense Prod. Division	Clifton, N. J.
70674	ADC Products Inc.	Minneapolis, Minn.	76005	Lord Mfg. Co.	Erie, Pa.	82209	Maguire Industries, Inc.	Greenwich, Conn.
70903	Belden Mfg. Co.	Chicago, Ill.	76210	C. W. Marwedel	San Francisco, Calif.	82219	Sylvania Electric Prod. Inc. Electronic Tube Division	Emporium, Pa.
70998	Bird Electronic Corp.	Cleveland, Ohio	76433	General Instrument Corp., Micamold Division	Newark, N. J.	82376	Astron Corp.	East Newark, Harrison, N. J.
71002	Birnback Radio Co.	New York, N. Y.	76487	James Millen Mfg. Co., Inc.	Malden, Mass.	82389	Switchcraft, Inc.	Chicago, Ill.
71041	Boston Gear Works Div. of Murray Co. of Texas	Quincy, Mass.	76493	J. W. Miller Co.	Los Angeles, Calif.	82647	Metals & Controls Inc. Spencer Products	Attleboro, Mass.
71218	Bud Radio, Inc.	Willoughby, Ohio	76530	Cinch-Monadnock, Div. of United Carr Fastener Corp.	San Leandro, Calif.	82768	Phillips-Advance Control Co.	Joliet, Ill.
71286	Camloc Fastener Corp.	Paramus, N. J.	76545	Mueller Electric Co.	Cleveland, Ohio			
71313	Cardwell Condenser Corp.	Lindenhurst L. J., N. Y.	76703	National Union	Newark, N. J.			
71400	Bussmann Mfg. Div. of McGraw-Edison Co.	St. Louis, Mo.	76854	Oak Manufacturing Co.	Crystal Lake, Ill.			
71436	Chicago Condenser Corp.	Chicago, Ill.	77068	Bendix Corp., The				
71447	Calif. Spring Co., Inc.	Pico-Rivera, Calif.		Bendix Pacific Div.	N. Hollywood, Calif.			

TABLE 6-3.
CODE LIST OF MANUFACTURERS (Cont'd)

Code No.	Manufacturer	Address	Code No.	Manufacturer	Address	Code No.	Manufacturer	Address
82866	Research Products Corp.	Madison, Wis.	91345	Miller Dial & Nameplate Co.	El Monte, Calif.	96341	Microwave Associates, Inc.	Burlington, Mass.
82877	Rotron Mfg. Co., Inc.	Woodstock, N.Y.	91418	Radio Materials Co.	Chicago, Ill.	96501	Excel Transformer Co.	Oakland, Calif.
82893	Vectro Electronic Co.	Glendale, Calif.	91506	Augat Inc.	Attleboro, Mass.	97464	Industrial Retaining Ring Co.	Irvington, N.J.
83053	Western Washer Mfg. Co.	Los Angeles, Calif.	91637	Dale Electronics, Inc.	Columbus, Nebr.	97539	Automatic & Precision Mfg.	Englewood, N.J.
83058	Carr Fastener Co.	Cambridge, Mass.	91662	Elco Corp.	Willow Grove, Pa.	97979	Reon Resistor Corp.	Yonkers, N.Y.
83086	New Hampshire Ball Bearing, Inc.	Peterborough, N.H.	91737	Gremer Mfg. Co., Inc.	Wakefield, Mass.	97983	Litton System Inc., Adler-Westrex Commun. Div.	New Rochelle, N.Y.
83125	General Instrument Corp., Capacitor Div.	Darlington, S.C.	91827	K F Development Co.	Redwood City, Calif.	98141	R-Tronics, Inc.	Jamaica, N.Y.
83148	ITT Wire and Cable Div.	Los Angeles, Calif.	91886	Malco Mfg. Co., Inc.	Chicago, Ill.	98159	Rubber Teck, Inc.	Gardena, Calif.
83186	Victory Eng. Corp.	Springfield, N.J.	91929	Honeywell Inc., Micro Switch Div.	Freeport Ill.	98270	Hewlett-Packard Co., Moseley Div.	Pasadena, Calif.
83298	Bendix Corp., Red Bank Div.	Red Bank, N.J.	91961	Nahm-Bros. Spring Co.	Oakland, Calif.	98278	Microdot, Inc.	So. Pasadena, Calif.
83315	Hubbell Corp.	Mundelein, Ill.	92180	Tru-Connector Corp.	Peabody, Mass.	98291	Sealectro Corp.	Mamaroneck, N.Y.
83330	Smith, Herman H., Inc.	Brooklyn, N.Y.	92367	Elgeet Optical Co. Inc.	Rochester, N.Y.	98376	Zero Mfg. Co.	Burbank, Calif.
83332	Tech Labs	Palisade's Park, N.J.	92396	Universal Industries, Inc.	City of Industry, Calif.	98731	General Mills Inc., Electronics Div.	Minneapolis, Minn.
83385	Central Screw Co.	Chicago, Ill.	92607	Tensolite Insulated Wire Co., Inc.	Tarrytown, N.Y.	98734	Paeco Div. of Hewlett-Packard Co.	Palo Alto, Calif.
83501	Gavitt Wire and Cable Co. Div. of Amerace Corp.	Brookfield, Mass.	92702	IMC Magnetics Corp.	Wesbury Long Island, N.Y.	98821	North Hills Electronics, Inc.	Glen Cove, N.Y.
83594	Burroughs Corp. Electronic Tube Div.	Plainfield, N.J.	92966	Hudson Lamp Co.	Kearney, N.J.	98978	International Electronic Research Corp.	Burbank, Calif.
83740	Union Carbide Corp. Consumer Prod. Div.	New York, N.Y.	93369	Robbins and Myers, Inc.	New York, N.Y.	99109	Columbia Technical Corp.	New York, N.Y.
83777	Model Eng. and Mfg., Inc.	Huntington, Ind.	93410	Stevens Mfg. Co., Inc.	Mansfield, Ohio	99313	Varian Associates	Palo Alto, Calif.
83821	Loyd Scruggs Co.	Festus, Mo.	93929	G. V. Controls	Livingston, N.J.	99378	Atlee Corp.	Winchester, Mass.
83942	Aeronautical Inst. & Radio Co.	Lodi, N.J.	94137	General Cable Corp.	Bayonne, N.J.	99515	Marshall Ind. Elect. Products Div.	San Marino, Calif.
84171	Arco Electronics Inc.	Great Neck, N.Y.	94144	Raytheon Co., Comp. Div., Ind. Comp. Operations	Quincy, Mass.	99707	Control Switch Division, Controls Co. of America	El Segundo, Calif.
84396	A. J. Glesener Co., Inc.	San Francisco, Calif.	94148	Scientific Electronics Products, Inc.	Loveland, Colo.	99800	Delevan Electronics Corp.	East Aurora, N.Y.
84411	TRW Capacitor Div.	Ogallala, Neb.	94154	Tung-Sol Electric, Inc.	Newark, N.J.	99848	Wilco Corporation	Indianapolis, Ind.
84970	Sarkes Tarzian, Inc.	Bloomington, Ind.	94197	Curtiss-Wright Corp. Electronics Div.	East Paterson, N.J.	99934	Renbrandt, Inc.	Boston, Mass.
85454	Boonton Molding Company	Boonton, N.J.	94222	South Chester Corp.	Chester, Pa.	99942	Hoffman Electronics Corp. Semiconductor Div.	El Monte, Calif.
85471	A. B. Boyd Co.	San Francisco, Calif.	94310	Tru-Ohm Products Memcor Components Div.	Huntington, Ind.	99957	Technology Instrument Corp. of Calif.	Newbury Park, Calif.
85474	R.M. Bracamonte & Co.	San Francisco, Calif.	94330	Wire Cloth Products, Inc.	Bellwood, Ill.			
85660	Koiled Kords, Inc.	Hamden, Conn.	94682	Worcester Pressed Aluminum Corp.	Worcester, Mass.			
85911	Seamless Rubber Co.	Chicago, Ill.	94696	Magnecraft Electric Co.	Chicago, Ill.			
86197	Clifton Precision Products Co., Inc.	Clifton Heights, Pa.	95023	George A. Philbrick Researchers, Inc.	Boston, Mass.			
86579	Precision Rubber Products Corp.	Dayton, Ohio	95236	Allies Products Corp.	Miami, Fla.			
86684	Radio Corp. of America, Electronic Comp. & Devices Div.	Harrison, N.J.	95238	Continental Connector Corp.	Woodside, N.Y.			
87034	Marco Industries	Anaheim, Calif.	95263	Leecraft Mfg. Co., Inc.	Long Island, N.Y.			
87216	Philco Corporation (Lansdale Division)	Lansdale, Pa.	95264	Lerc Electronics, Inc.	Burbank, Calif.			
87473	Western Fibrous Glass Products Co.	San Francisco, Calif.	95265	National Coil Co.	Sheridan, Wyo.			
87664	Van Waters & Rogers Inc.	San Francisco, Calif.	95275	Vitramon, Inc.	Bridgeport, Conn.			
87930	Tower Mfg. Corp.	Providence, R.I.	95348	Gordos Corp.	Bloomfield, N.J.			
88140	Cutler-Hammer, Inc.	Lincoln, Ill.	95354	Method Mfg. Co.	Chicago, Ill.			
88220	Gould-National Batteries, Inc.	St. Paul, Minn.	95566	Arnold Engineering Co.	Marengo, Ill.			
88421	Federal Telephone & Radio Corp.	Clifton, N.J.	95712	Dage Electric Co., Inc.	Franklin, Ind.			
88698	General Mills, Inc.	Buffalo, N.Y.	95984	Siemon Mfg. Co.	Wayne, Ill.			
89231	Graybar Electric Co.	Oakland, Calif.	95987	Weckesser Co.	Chicago, Ill.			
89665	United Transformer Co.	Chicago, Ill.	96067	Huggins Laboratories	Sunnyvale, Calif.			
90179	US Rubber Co., Consumer Ind. & Plastics Prod. Div.	Passaic, N.J.	96095	Hi-Q Div. of Aerovox Corp.	Olean, N.Y.			
90970	Bearing Engineering Co.	San Francisco, Calif.	96256	Thordarson-Meissner Inc.	Mt. Carmel, Ill.			
91146	ITT Cannon Elect. Inc., Salem Div.	Salem, Mass.	96296	Solar Manufacturing Co.	Los Angeles, Calif.			
91260	Connor Spring Mfg. Co.	San Francisco, Calif.	96330	Carlton Screw Co.	Chicago, Ill.			

THE FOLLOWING HP VENDORS HAVE NO NUMBER ASSIGNED IN THE LATEST SUPPLEMENT TO THE FEDERAL SUPPLY CODE FOR MANUFACTURERS HANDBOOK.

0000F	Malco Tool and Die	Los Angeles, Calif.
0000Z	Willow Leather Products Corp.	Newark, N.J.
000AB	ETA	England
000BB	Precision Instrument Components Co.	Van Nuys, Calif.
000CS	Hewlett-Packard Co.,	Colorado Springs
		Colorado Springs, Colorado
000MM	Rubber Eng. & Development	Hayward, Calif.
000NN	A "N" D Mfg. Co.	San Jose, Calif.
000QQ	Cooltron	Oakland, Calif.
000WW	California Eastern Lab.	Burlington, Calif.
000YY	S. K. Smith Co.	Los Angeles, Calif.

**TABLE 6-4. PART NUMBER - NATIONAL STOCK NUMBER
CROSS REFERENCE INDEX**

PART NUMBER	FSCM	NATIONAL STOCK NUMBER	PART NUMBER	FSCM	NATIONAL STOCK NUMBER
D36254	56289	5910-00-067-8305	0370-0118	28480	5355-00-071-8948
RDM15F221J3C	14655	5910-00-919-0166	0410-0013	28480	5955-00-084-8503
0121-0127	28480	5910-00-828-2061	0410-0108	28480	5955-00-158-5139
0121-0166	28480	5910-00-247-8600	0410-0109	28480	5955-00-158-5143
0140-0145	28480	5910-00-257-0227	0698-0082	28480	5905-00-974-6075
0140-0176	28480	5910-00-902-2576	0698-0083	28480	5905-00-407-0052
0140-0192	28480	5910-00-914-4730	0698-0084	28480	5905-00-974-6073
0140-0209	28480	5910-00-920-3776	0698-3136	28480	5905-00-891-4247
0140-0214	28480	5910-00-835-3251	0698-3154	28480	5905-00-891-4215
0140-0232	28480	5910-00-492-7544	0698-3156	28480	5905-00-974-6084
0150-0050	28480	5910-00-784-0927	0698-3430	28480	5905-00-420-7136
0150-0093	28480	5910-00-542-2010	0698-3440	28480	5905-00-828-0377
0150-0096	28480	5910-00-247-7226	0698-3441	28480	5905-00-974-6076
0150-0097	28480	5910-00-947-3782	0698-3445	28480	5905-00-493-4289
0150-0121	28480	5910-00-950-6822	0757-0280	28480	5905-00-853-8190
0160-0127	28480	5910-00-809-5484	0757-0346	28480	5905-00-998-1906
0160-0134	28480	5910-00-919-0166	0757-0401	28480	5905-00-981-7529
0160-0174	28480	5910-00-234-9817	0757-0416	28480	5905-00-998-1795
0160-0178	28480	5910-00-944-9429	0757-0417	28480	5905-00-858-9417
0160-0194	28480	5910-00-725-0495	0757-0439	28480	5905-00-990-0303
0160-0340	28480	5910-00-776-4078	0757-0441	28480	5905-00-858-6799
0160-2140	28480	5910-00-430-5625	0757-0465	28480	5905-00-904-4412
0160-2197	28480	5910-00-472-5027	0757-1094	28480	5905-00-917-0580
0160-2263	28480	5910-00-401-7891	08406-6012	28480	5985-01-032-2461
0160-2306	28480	5910-00-883-6281	08406-6013	28480	5950-00-262-6027
0180-0059	28480	5910-00-827-1218	08406-6014	28480	5950-00-262-6030
0180-0119	28480	5910-00-864-8416	1025-20	99800	5950-00-059-5920
0180-0138	28480	5910-00-067-8305	1200-0028	28480	5935-00-581-6941
0370-0103	28480	5355-00-721-8924	1205-0011	28480	5999-00-789-3794

**TABLE 6-4. PART NUMBER - NATIONAL STOCK NUMBER
CROSS REFERENCE INDEX (Continued)**

PART NUMBER	FSCM	NATIONAL STOCK NUMBER	PART NUMBER	FSCM	NATIONAL STOCK NUMBER
1250-0001	28480	5935-00-027-6759	5040-0700	28480	5340-00-978-7859
1250-0016	28480	5365-00-937-0638	5060-0703	28480	6625-00-412-1207
1250-0083	28480	5935-00-804-5144	8120-0078	28480	5995-00-995-9822
1251-0148	28480	5935-00-058-9423	8120-1348	28480	6150-01-004-8773
1251-2357	28480	5935-00-233-6728	9100-1612	28480	5950-00-438-4376
1400-0084	28480	5920-00-881-4636	9100-1613	28480	5950-00-431-3189
1850-0040	28480	5961-00-872-0882	9100-1680	28480	5950-00-107-6071
1850-0062	28480	5961-00-988-7630	9140-0131	28480	5950-00-431-3938
1853-0051	28480	5961-00-979-0108	9140-0158	28480	5950-00-059-5920
1854-0005	28480	5961-00-853-7942	9140-0210	28480	5950-00-431-3215
1901-0025	28480	5961-00-978-7468			
1901-0026	28480	5961-00-060-8638			
1901-0040	28480	5961-00-965-5917			
1912-0007	28480	5961-00-904-0298			
2N708	07263	5961-00-866-4810			
2100-0067	28480	5905-00-850-6556			
2100-0350	28480	5905-00-351-6128			
2140-0047	28480	6240-00-912-5186			
2140-0244	28480	6240-00-951-3376			
30D106G025BB4	56289	5910-00-889-4854			
3101-0033	28480	5930-00-977-1760			
3101-1234	28480	5930-00-406-8746			
3101-1248	28480	5930-00-476-9679			
342014	75915	5920-00-881-4636			
5C11A	56289	5910-00-883-0838			
5020-0306	28480	5935-00-931-0420			
5040-0234	28480	6250-00-910-8305			
5040-0235	28480	6250-00-933-7369			

SECTION VII

SCHEMATIC DIAGRAMS

7-1. INTRODUCTION.

7-2. This section contains schematic diagrams. Figure 7-1 lists notes and symbols which apply to all schematic diagrams. Each diagram follows the guide lines listed below.

a. Schematics in this manual are meant to show electrical circuit operation and not intended as wiring diagrams.

b. Assembly sections of schematics may or may not be shaded as in the example shown.

7-3. REPLACEMENT INFORMATION.

7-4. For repair and replacement information, refer to the MAINTENANCE section of this manual which is Section V. For specific component descriptions refer to page 6-1.

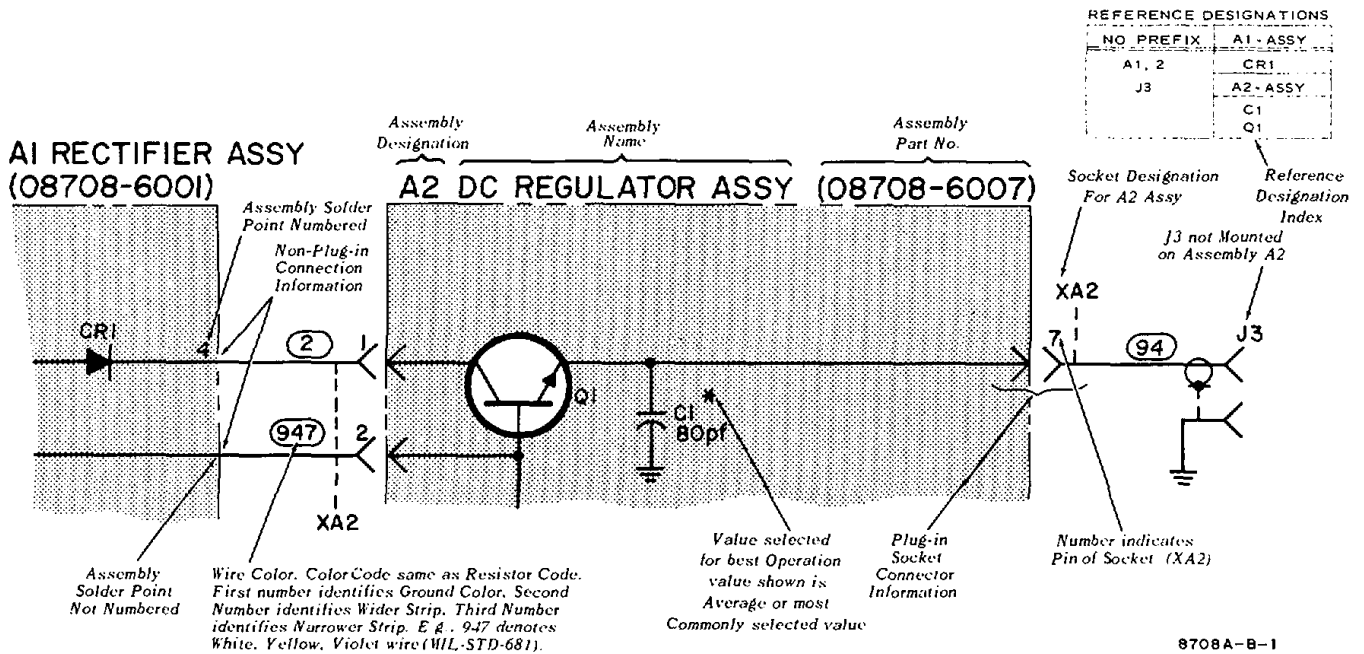

Figure 7-1. Schematic Information Illustration

SECTION VIII

BACKDATING INFORMATION

This manual applies to instruments with Serial Prefixes 649-, and 737-. Listed below are changes to be made to the manual so that it will apply directly to Prefixes 532-, and 541-.

Instrument Serial No. Prefix	Change Number
541-	1
532-	1 and 2

CHANGE 1:

Table 6-1 Page	Table 6-2 Page	Schematic Page	Delete, Change, or add	Circuit Ref.	Stk No.	Item Description	
6-2	6-7	7-3/7-4	Change	A1C7	0121-0031	C: Var 1.85-10.38 pF	
"	"	"	"	A1C18	"	"	
"	"	"	"	A1C39	"	"	
CHANGE 2:	6-7	6-7	7-3/7-4	Change	A1C29	0160-0370	20 pF 5%
	6-3		"	"	A1L11	9100-1612	0.33 μ H
	"		"	"	A1Q5	1854-0031	2N2865
	"		"	"	A1Q7	1854-0031	2N2865
	"		"	"	A1R20	0698-3156	14.7 K Ω
	"		"	"	A1R21	0698-3155	4640 Ω
	"		"	"	A1R22	0698-0084	2150 Ω
	6-2		Delete	A1C41	-	-	
	6-3		"	A1R31	-	-	
	"		"	A1R32	-	-	

MANUAL IDENTIFICATION

Model Number: 8406A
Date Printed: JUNE 1967
Part Number: 08406-90001

This supplement contains important information for correcting manual errors and for adapting the manual to instruments containing improvements made after the printing of the manual.

To use this supplement:
 Make all ERRATA corrections
 Make all appropriate serial number related changes indicated in the tables below.

Serial Prefix or Number	Make Manual Changes
737-00386 thru 737-00555	1, 2
737-00556 thru 737-00585	1, 2, 3
737-00586 thru 737-00675	2, 3, 4

▶ NEW ITEM

ERRATA

Serial Prefix or Number	Make Manual Changes
961-, 0961A	3, 4, 5
1145A	3, 4, 5, 6
1441A01266 thru 1441A01275	3, 4, 5, 6, 7
1441A01276 thru 1441A Prefix	3, 4, 5, 6, 7, 8
▶ 1628A, 1632A	3, 4, 5, 6, 7, 8, 9

Page 1-1, General Information:
 Add the following information preceding Paragraph 1-1:

1-A. SAFETY CONSIDERATIONS

General

This instrument has been designed and tested according to IEC Publication 348, "Safety Requirements for Electronic Measuring Apparatus," and has been supplied in safe condition. This is a Safety Class I instrument.

Operation

BEFORE APPLYING POWER, make sure the instrument's ac input is set for the available ac line voltage, that the correct fuse is installed, and that all normal safety precautions have been taken.

Service

Although the instrument has been designed in

NOTE

Manual change supplements are revised as often as necessary to keep manuals as current and accurate as possible. Hewlett-Packard recommends that you periodically request the latest edition of this supplement. Free copies are available from all HP offices. When requesting copies quote the manual identification information from your supplement, or the model number and print date from the title page of the manual.

AUGUST 1976

Printed in U.S.A.

ERRATA (Cont'd)

accordance with international safety standards, the information, cautions, and warnings in this manual must be followed to ensure safe operation and to keep the instrument safe. Service and adjustments should be performed only by qualified service personnel.

Adjustment or repair of the opened instrument with the ac power connected should be avoided as much as possible and, when inevitable, should be performed only by a skilled person who knows the hazard involved.

Capacitors inside the instrument may still be charged even though the instrument has been disconnected from its source of supply.

Make sure only fuses of the required current rating and type (normal blow, time delay, etc.) are used for replacement. Do not use repaired fuses or short circuit the fuse holders.

Whenever it is likely that the protection has been impaired, make the instrument inoperative and secure it against any unintended operation.

ERRATA (cont'd)

Page 5-3, Table 5-2, step e:

Change 10-MC to read 1 MC.

Page 6-3, Table 6-1:

Change to read:

A1T1 08406-6013 Transformer: RF (Oscillator)

Page 6-4, Table 6-1:

Change to read:

A1T2 08406-6014 Transformer: RF (Amplifier)

Page 6-4, Table 6-1 and page 6-9, Table 6-2:

Add to Z1 Attenuator Pad Assy: Spacer 2 ea 08491-2102

Page 6-4, Table 6-1 and page 6-7, Table 6-2:

Change J1, J2 to read: 1250-0001 Connector: BNC

Page 6-4, Table 6-1; page 6-7, Table 6-2 and page 7-3/7-4, Figure 7-2:

Change R1 to read: 2100-0350 R:VAR COMP 1.5K OHM 20% LIN 1/2W

Page 6-9, Table 6-2:

Add: 08406-6013 Transformer: RF (Oscillator)

08406-6014 Transformer: RF (Amplifier)

CHANGE 1

Page 6-2, Table 6-1; Page 6-7, Table 6-2; Page 7-3/7-4, Figure 7-2:

Change A1C17 to C: FXD MICA 33 pF 300 V 5% 0160-0179

CHANGE 2

Page 6-4, Table 6-1; Page 6-8, Table 6-2; Page 7-3/7-4, Figure 7-2:

Change R1 to R:VAR COMP' 1500 OHM 20% LIN 1/2W 2100-0350

CHANGE 3

Page 6-3, Table 6-1; Page 7-5/7-6, Figure 7-3:

Change to read: A1Q8 1850-0040 Transistor: Germanium PNP

A1Q9 1853-0051 Transistor: Silicon 2N4037

A1R30 0683-0395 R:FXD COMP 3.9 OHM 5% 1/4W

Page 6-4, Table 6-1:

Change to read:

A1VR1 1902-320C3 DIODE BREAKDOWN: SILICON.14.7V 5% 400 mW

Add:

A1MP1 1205-0011 HEAT DISSIPATOR: TO-5/9 CASE USED ON A1Q9

CHANGE 4

Page 6-2, Table 6-1; Page 7-3/7-4, Figure 7-2:

Change to read: A1C7 0120-0166 C:VAR AIR, 2.4 TO 24.5 pF
A1C17 0160-2263 C: FXD CER, 18 pF 5% 500 VDCW
A1C18 0121-0166 C:VAR, AIR 2.4 TO 24.5 pF

CHANGE 5

Page 6-4, Table 6-1:

Change to read: DS1 2140-0244 LAMP: GLOW 1.0 mA TYPE A1H P/0 S3
F1 2110-0311 FUSE: CARTRIDGE 1/16 AMP TYPE MDL-1/16
J3 1251-2357 CONNECTOR: POWER 3 PIN MALE
R1 2100-0067 R:VAR COMP 2.5K OHM 20% LIN 1/2W
S1 3101-1248 SWITCH: PUSHBUTTON (LINE)
S2 3101-1234 SWITCH: SLIDE DPDT 115/230V

Page 6-5, Table 6-1:

Change 8120-0078 to read: 8120-1348 CABLE ASSY: POWER
Delete: 5040-0234 LAMPHOLDER
5040-0235 BASE: LAMPHOLDER

Page 6-6, Table 6-1:

Change to read: 9 08406-0015 PANEL: REAR
10 08406-00016 PANEL: FRONT

Page 7-5/7-6, Figure 7-3:

Change schematic as indicated below:

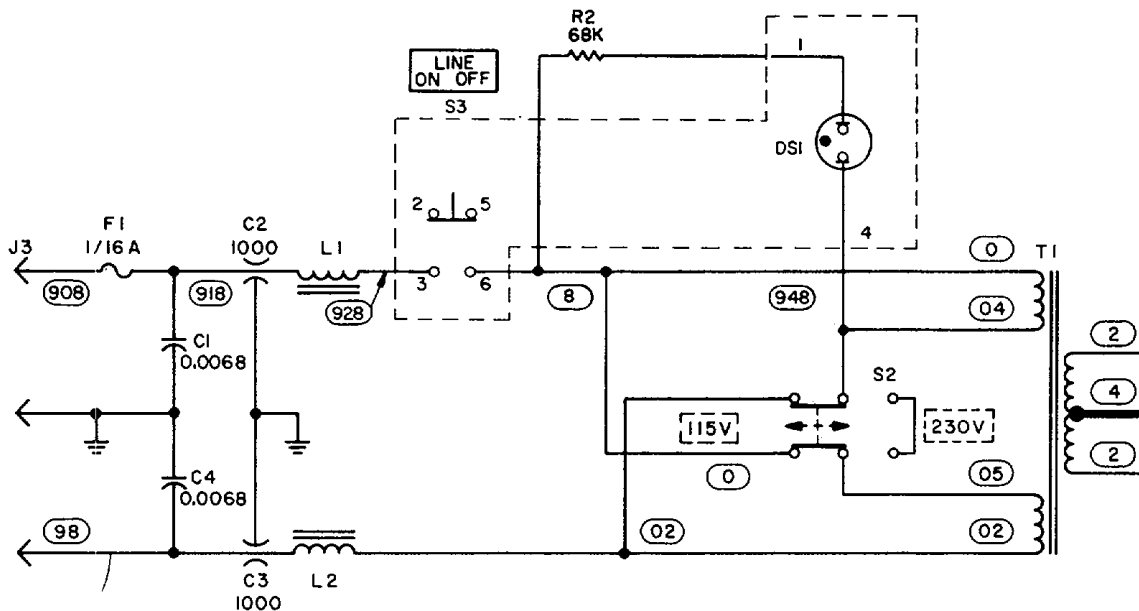

P/O Figure 7-3. (Change 5)

CHANGE 6

Page 6-2, Table 6-1 and Page 7-3/7-4, Figure 7-2:

Change A1C17 to C: FXD MICA 60 pF 300 V 5% 0140-0214 (*) Factory Selected Component.

Page 6-5, Table 6-1:

Add: 0370-1400 KNOB: MINT GRAY PUSHBUTTON 11116 IN DIA 1MC, 10MC, 100MC EXT TRIG.

Page 6-6, Table 6-1 Cabinet Parts:

Change items 6 through 10 to read:

6	5000-8565 5000-0703	COVER: SIDE (OLIVE GRAY) COVER: SIDE (BLUE GRAY)
7	5060-8555 5060-0709	COVER ASSEMBLY:TOP (OLIVE GRAY) COVER ASSEMBLY:TOP (BLUE GRAY)
8	5000-8571 5000-0700	COVER ASSEMBLY:BOTTOM (OLIVE GRAY) COVER ASSEMBLY:BOTTOM (BLUE GRAY)
9	08406-00015	PANEL: REAR
10	08406-00017 08406-00016	PANEL: FRONT (MINT GRAY) PANEL: FRONT (LIGHT GRAY)

CHANGE 7

Page 6-4, Table 6-1:

Change RI to 2100-2769, R:VAR 2.5K OHM 20% 2W.

CHANGE 8

Page 6-2, Table 6-1:

Change A1C6 to 0160-2306, C:FXD CER 27 pF 5% 300 V, Factory Selected Part.

Change A1C17 to 0140-0145, C: FXD MICA 22 pF 5% 500 VDCW, Factory Selected Part.

Page 7-3, Figure 7-2:

Change the value of A1C6 to A1C6* 27 pF.

Change the value of A1C17* to 22 pF.

>CHANGE 9

Page 1-1, Table 1-1:

Change "Peak amplitude*" to "Typical amplitude*".

8-7/(8-8 blank)

APPENDIX A REFERENCES

The following publications contain information applicable to the operation and maintenance of the SG-1129/U (HP-8406A) Frequency Comb Generator.

TM 11-6625-2781-14&P	Operator's, Organizational, Direct Support, and General Support Maintenance Manual Including Repair Parts and Special Tools List: Spectrum Analyzer IP-1216(P)/GR (HP-141T)
TM 11-6625-700-10	Operator's Manual: Digital Readout, Electronic Counter AN/USM-207
TM 11-6625-573-14	Operator's, Organizational, Direct Support, and General Support Maintenance Manual: Generator Signal AN/GRM-50
TM 11-6625-1633-12	Operator's and Organizational Maintenance Manual Including Repair Parts and Special Tools List: Generator, Signal AN/URM-149
TM 11-6625-320-12	Operator's and Organizational Maintenance Manual: Voltmeter, Meter ME-30()/U
TM 11-6625-444-14-1	Operator's, Organizational, Direct Support, and General Support Maintenance Manual Including Repair Parts and Special Tools List: Voltmeter Digital AN/GSM-64B
TM 11-6625-524-14	Operator's, Organizational, and Field Maintenance Manual: Voltmeter, Electronic AN/URM-145
AR 55-38	Reporting of Transportation Discrepancies in Shipment
AR735-11-2	Reporting of Item Discrepancies Attributable to Shippers
DA PAM 310-4	Index of Technical Publications: Technical Manuals, Technical Bulletins, Supply Manuals (Types 7, 8 and 9), Supply Bulletins, and Lubrication Orders
DA PAM 310-7	US Army Equipment Index of Modification Work Orders
MIL-F-14702	Finishes for Ground Signal Equipment
SB 11-573	Painting and Preservation Supplies Available for Field Use for Electronics Command Equipment

APPENDIX A - Continued

SB 38-100	Preservation, Packaging and Packing Materials, Supplies and Equipment Used by the Army
SB 700-20	Army Adopted/Other Items Selected for Authorization/List of Reportable Items
TB SIG 222	Solder and Soldering
TM 38-750	The Army Maintenance Management System (TAMMS)
TM 750-244-2	Procedures for Destruction of Electronics Materiel to Prevent Enemy Use (Electronics Command)

APPENDIX D

MAINTENANCE ALLOCATION

Section I. INTRODUCTION

D-1. General

This appendix provides a summary of the maintenance operations for the SG-1129/U (HP-8406A). It authorizes categories of maintenance for specific maintenance functions on repairable items and components and the tools and equipment required to perform each function. This appendix may be used as an aid in planning maintenance operations.

D-2. Maintenance Function

Maintenance functions will be limited to and defined as follows:

a. Inspect. To determine the serviceability of an item by comparing its physical, mechanical, and/or electrical characteristics with established standards through examination.

b. Test. To verify serviceability and to detect incipient failure by measuring the mechanical or electrical characteristics of an item and comparing those characteristics with prescribed standards.

c. Service. Operations required periodically to keep an item in proper operating condition, i.e., to clean (decontaminate), to preserve, to drain, to paint, or to replenish fuel, lubricants, hydraulic fluids, or compressed air supplies.

d. Adjust. To maintain, within prescribed limits, by bringing into proper or exact position, or by setting the operating characteristics to the specified parameters.

e. Align. To adjust specified variable elements of an item to bring about optimum or desired performance.

f. Calibrate. To determine and cause corrections to be made or to be adjusted on instruments or test measuring and diagnostic equipments used in precision measurement. Consists of comparisons of two instruments, one of which is a certified standard of known accuracy, to detect and adjust any discrepancy in the accuracy of the instrument being compared.

g. Install. The act of emplacing, seating, or fixing into position an item, part, module (component or assembly) in a manner to allow the proper functioning of the equipment or system.

h. Replace. The act of substituting a serviceable like type part, subassembly, or module (component or assembly) for an unserviceable counterpart.

i. Repair. The application of maintenance services (inspect, test, service, adjust, align, calibrate, replace) or other maintenance actions (welding, grinding, riveting, straightening, facing, remachining, or resurfacing) to restore serviceability to an item by correcting specific damage, fault, malfunction, or failure in a part, subassembly, module (component or assembly), end item, or system.

j. Overhaul. That maintenance effort (service/action) necessary to restore an item to a completely serviceable/operational condition as prescribed by maintenance standards (i.e. DMWR) in appropriate technical publications. Overhaul is normally the highest degree of maintenance performed by the Army. Overhaul does not normally return an item to like new condition.

k. Rebuild. Consists of those services/actions necessary for the restoration of unserviceable equipment to a like new condition in accordance with original manufacturing standards. Rebuild is the highest degree of material maintenance supplied to Army equipment. The rebuild operation includes the act of returning to zero those age measurements (hours, miles, etc.) considered in classifying Army equipments/components.

D-3. Column Entries.

a. Column 1, Group Number. Column 1 lists group numbers, the purpose of which is to identify components, assemblies, subassemblies, and modules with the next higher assembly.

b. Column 2, Component/Assembly. Column 2 contains the noun names of components, assemblies, subassemblies, and modules for which maintenance is authorized.

c. Column 3, Maintenance Functions. Column 3 lists the functions to be performed on the item listed in column 2. When items are listed with-out maintenance functions, it is solely for the purpose of having the group numbers in the MAC and RPSTL coincide.

d. Column 4, Maintenance Category. Column 4 specifies, by the listing of a "work time" figure in the appropriate subcolumn(s), the lowest level of maintenance authorized to perform the function listed in column 3. This figure represents the active time required to perform that maintenance function at the indicated category of maintenance. If the number or complexity of the tasks within the listed maintenance function vary at different maintenance categories, appropriate "work time" figures will be shown for each category. The number of task-hours specified by the "work time" figure represents the average time required to restore an item

(assembly, subassembly, component, module, end item or system) to a serviceable condition under typical field operating conditions. This time includes preparation time, troubleshooting time, and quality assurance/quality control time in addition to the time required to perform the specific tasks identified for the maintenance functions authorized in the maintenance allocation chart. Subcolumns of column 4 are as follows:

C - Operator/Crew

O - Organizational

F - Direct Support

H - General Support

D - Depot

e. Column 5, Tools and Equipment. Column 5 specifies by code those common tool sets (not individual tools) and special tools, test, and support equipment required to perform the designated function.

f. Column 6, Remarks. Column 6 contains an alphabetic code which leads to the remark in Section V, Remarks, which is pertinent to the item opposite the particular code.

D-4. Tool and Test Equipment Requirements (Section III)

a. Tool or Test Equipment Reference Code. The numbers in this column coincide with the numbers used in the tools and equipment column of the MAC. The numbers indicate the applicable tool or test equipment for the maintenance functions.

b. Maintenance Category. The codes in this column indicate the maintenance category allocated the tool or test equipment.

c. Nomenclature. This column lists the noun name and nomenclature of the tools and test equipment required to perform the maintenance functions.

d. National/NATO Stock Number. This column lists the National/NATO stock number of the specific tool or test equipment.

e. Tool Number. This column lists the manufacturer's part number of the tool followed by the Federal Supply Code for manufacturers (5-digit) in parentheses.

D-5. Remarks (Section V)

- a. Reference Code. This code refers to the appropriate item in Section II, column 6.
- b. Remarks. This column provides the required explanatory information necessary to clarify items appearing in Section II.

**SECTION II. MAINTENANCE ALLOCATION CHART
FOR
HP 8406A Frequency Comb Generator**

(1) GROUP NUMBER	(2) COMPONENT ASSEMBLY	(3) MAINTENANCE FUNCTION	(4) MAINTENANCE CATEGORY					(5) TOOLS AND EQUIPMENT	(6) REMARKS
			C	O	F	H	D		
00	Frequency Generator	Inspect		0.1				Visual, External Simple, Opera- tional	
		Test		0.2					
		Test				0.5		12	
		Adjust				0.4		12	
		Install		0.1				13	
		Replace		0.1				13	
		Repair				1.0		1 thru 9	
		Overhaul				3.0		1 thru 12	

**SECTION III. TOOL AND TEST EQUIPMENT REQUIREMENTS
FOR
HP 8406A Frequency Comb Generator**

TOOL OR TEST EQUIPMENT REF CODE	MAINTENANCE CATEGORY	NOMENCLATURE	NATIONAL/ NATO STOCK NUMBER	TOOL NUMBER
1	H,D	Analyzer, Spectrum IP-1216/PGR	6625-00-424-4370	
2	H,D	Plug-In PL-1400/U	6625-00-422-4314	
3	H,D	Counter, Frequency, Electronic AN/USM-207	6625-00-044-3228	
4	H,D	Generator, Signal AN/GRM-SOC	6625-00-003-3238	
5	H,D	Generator, Signal AN/URM-149	6625-00-903-3501	
6	H,D	Multimeter ME-30E/U	6625-00-643-1670	
7	H,D	Voltmeter AN/GSM-64	6625-00-022-7894	
8	H,D	Voltmeter AN/URM-145	6625-00-973-3986	
9	H,D	Transformer, Variable, Power CN-16/U	5950-00-235-2086	
10	D	Notch Filter HP 8439A or equal		
11	D	Bandpass Filter HP 8431A or equal		
12	H,D	Tool Kit TK-100/G Common tools necessary for the performance of this maintenance function are available to maintenance personnel for the maintenance category listed.	5180-00-605-0079	

By Order of the Secretary of the Army:

Official:

J. C. PENNINGTON
Major General, United States Army
The Adjutant General

E. C. MEYER
General, United States Army
Chief of Staff

Distribution:

Active Army:

HISA (Ft Monmouth) (21)
USAINSCOM (2)
COE (1)
TSG (1)
DARCOM (1)
TRADOC (2)
OS Maj Comd (4)
TECOM (2)
USAACC (4)
MDW (1)
Armies (2)
Corps (2)
Svc Colleges (1)
USASIGS (5)
USAADS (2)
USAFAS (2)
USAARMS (2)
USAIS (2)

USAES (2)
USAICS (3)
MAAG (1)
USARMIS (1)
USAERDAW (1)
Ft Carson (5)
Ft Gordon (10)
Ft Gillem (10)
Ft Richardson (CERCOM Ofc) (2)
Army Dep (1) except
 SAAD (30)
 TOAD (14)
 SHAD (2)
USA Dep (1)
Sig Sec USA Dep (1)
Units org under fol TOE: (2)
 29-207
 29-610

NG: None
USAR: None

For explanataion of abbreviations used see, AR 310-50.

Section VII
Figure 7-2

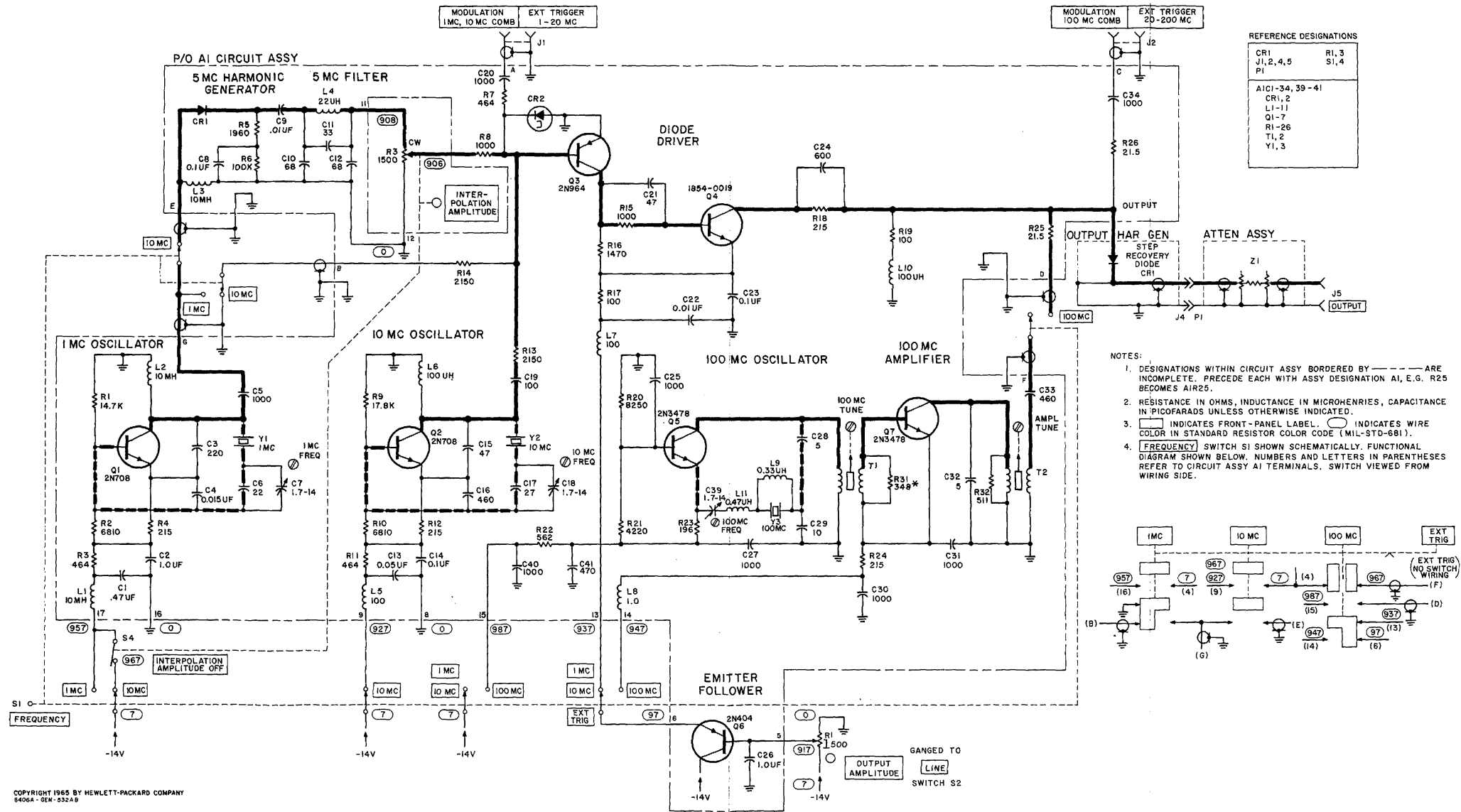
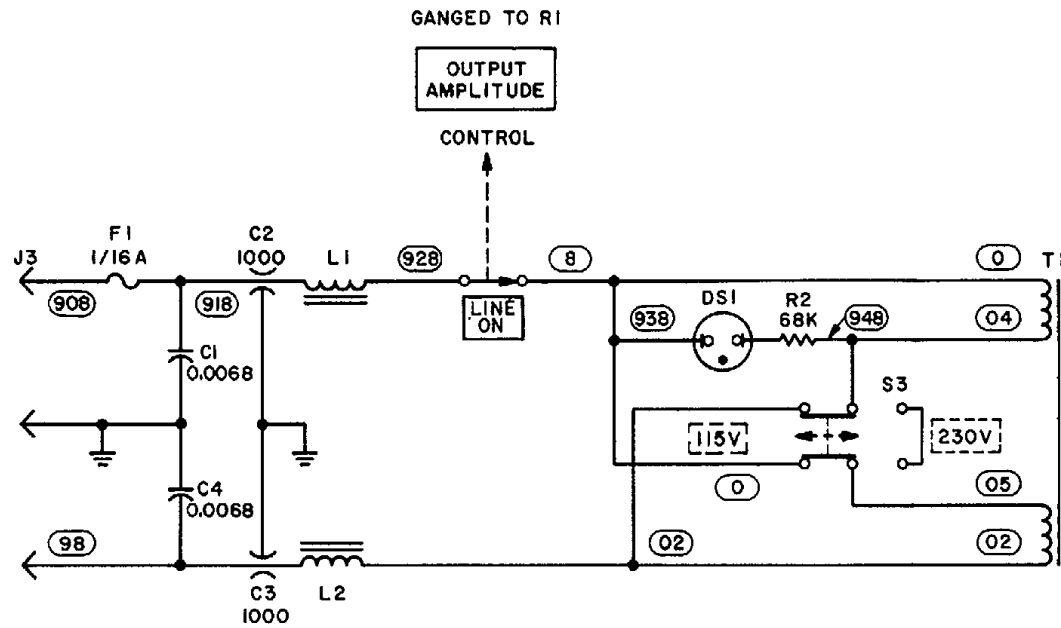

Figure 7-2. Generator



REFERENCE DESIGNATIONS

C1-4 DS1 F1 J3 L1,2 R2 S2,3 T1
A1C35-38 CR3-7 Q8,9 R27-30 VR1

P/O AI CIRCUIT ASSY

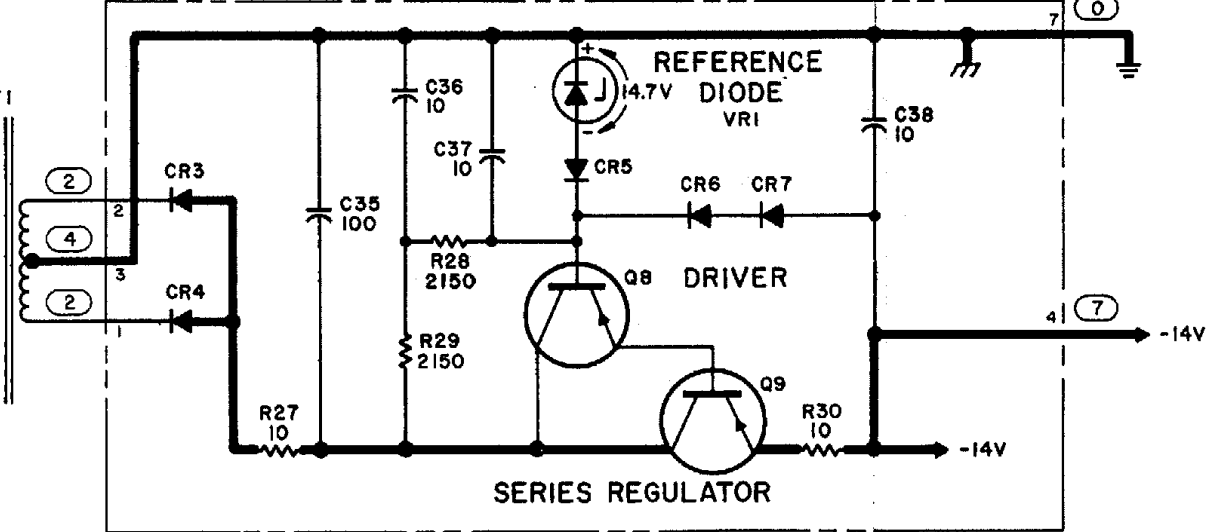

NOTES:

- DESIGNATIONS WITHIN CIRCUIT ASSY BORDERED BY - - - - ARE INCOMPLETE. PRECEED EACH WITH ASSY DESIGNATION AI, E.G. R26 BECOMES AIR26.
- RESISTANCE IN OHMS, CAPACITANCE IN MICROFARADS.
- | | |
|--|------------------------------|
| | INDICATES FRONT PANEL LABEL. |
| | INDICATES REAR PANEL LABEL. |

	INDICATES WIRE COLOR IN STANDARD RESISTOR COLOR CODE (MIL STD 681).
--	---

RECOMMENDED CHANGES TO EQUIPMENT TECHNICAL PUBLICATIONS



THEN... JOT DOWN THE DOPE ABOUT IT ON THIS FORM, CAREFULLY TEAR IT OUT, FOLD IT AND DROP IT IN THE MAIL!

SOMETHING WRONG WITH THIS PUBLICATION?

FROM: (PRINT YOUR UNIT'S COMPLETE ADDRESS)

DATE SENT

PUBLICATION NUMBER

PUBLICATION DATE

PUBLICATION TITLE

BE EXACT... PIN-POINT WHERE IT IS

PAGE NO.	PARA-GRAPH	FIGURE NO.	TABLE NO.
----------	------------	------------	-----------

IN THIS SPACE TELL WHAT IS WRONG AND WHAT SHOULD BE DONE ABOUT IT:

TEAR ALONG PERFORATED LINE

PRINTED NAME, GRADE OR TITLE, AND TELEPHONE NUMBER

SIGN HERE:

DA FORM 2028-2
1 JUL 79

PREVIOUS EDITIONS ARE OBSOLETE.

P.S.—IF YOUR OUTFIT WANTS TO KNOW ABOUT YOUR RECOMMENDATION MAKE A CARBON COPY OF THIS AND GIVE IT TO YOUR HEADQUARTERS.

PIN: 045625-000